

PAS EX CC (472 497)

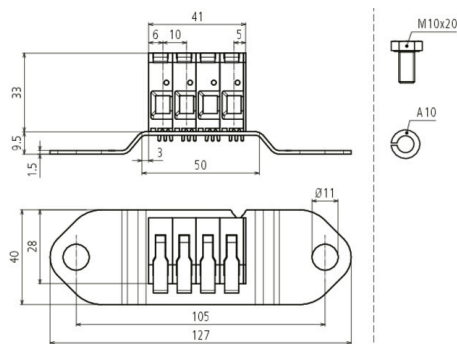
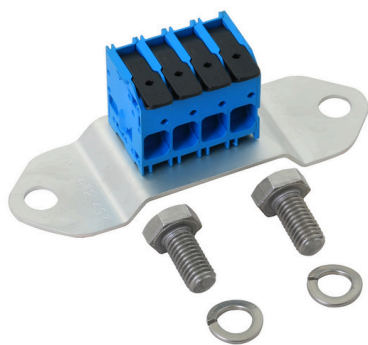

Figure without obligation

Push-in adapter for non-sparking, Ex equipotential bonding bar PAS EX for convenient connection of flexible conductors. For use in potentially explosive areas of Ex zones 1 and 2 (gases, vapours, mists) up to explosion group IIC as well as Ex zones 21 and 22 (dusts). Use indoors only permissible.

Type	PAS EX CC
Part No.	472 497 NEW
Material	Polyamide
Screw material	StSt
Screws	M10 x 20 mm
Screw type	with spring washer
Lightning impulse current (10/350 µs) Cu 4-16 mm ² (per core)	3 kA (non-sparking)
Lightning impulse current (10/350 µs) Cu 16 mm ² (per core)	25 kA
Nominal discharge current (8/20 µs) per core (I _n) Cu 4-10 mm ²	10 kA (non-sparking)
Nominal discharge current (8/20 µs) per core (I _n) Cu 16 mm ²	15 kA (non-sparking)
Weight	174 g
Customs tariff number	85389099
GTIN	4013364470484
PU	1 Stk

Note: Non-sparking only ensured in connection with PAS EX ...!

We reserve the right to introduce changes in performance, configuration and technology, dimensions, weights and materials in the course of technical progress. The figures are shown without obligation.