

Wall-/ceiling luminaire

Wall-/ceiling luminaire with homogenous light emitting surface, FLEX technology, IP65 for indoor and outdoor applications, Total luminous flux: 1200 lm, Luminaire input power: 11.5 W, Lamp efficacy: 104 lm/W. Colour rendering Ra > 80, colour temperature 3000/3500/4000 K adjustable via switch. Lifetime: 50.000h L80, Chromaticity tolerance (initial MacAdam): 4, Impact strength: IK10, compatible with Plug&Play Emergency kit for 3 hour emergency conversion. Bezel and eyelid trim available as accessory. Integrated microwave presence and daylight sensor including optional corridor function with standby level 10%. BESA compatible. Body: polycarbonate, white. Diffuser: polycarbonate, opal. Input power adjustable on site by 3 step (FLEX 1: 1200 lm (11,5W), FLEX 2 : 1000 lm (9,5W), FLEX 3: 800 lm (7,5W)). For flex data on other colour temperatures please visit website. Dimensions: Ø250 x 75 mm, weight: 1.1 kg.

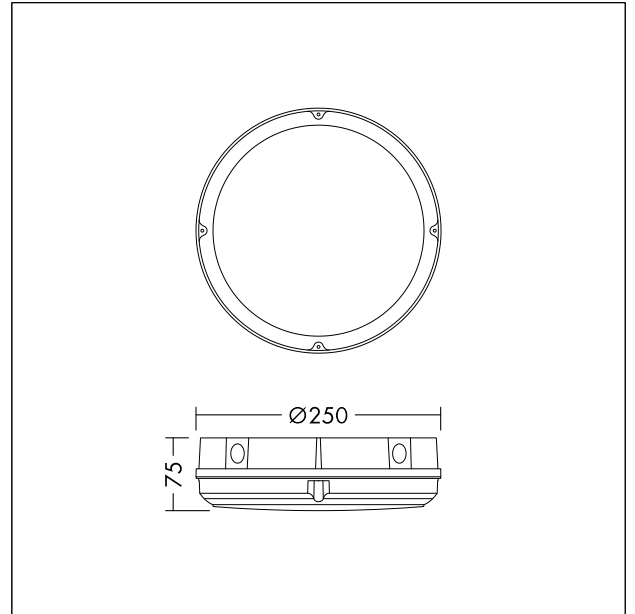

TE_LARAVARIOFLEX_F_250_BLANK_WH_persp.jpg



TE_LARAVARIOFLEX_M_250.wmf

Light Distribution

STD - standard

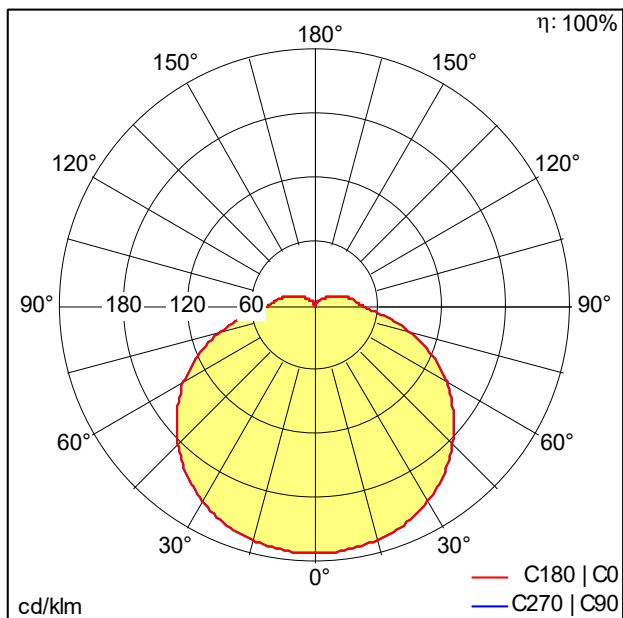

TE_LARA_VARIOFLEX_250_1200_840_FLEX1.idt

- Light Source: LED
- Luminaire luminous flux*: 1200 lm
- Total emergency luminous flux: 210 lm
- Luminaire efficacy*: 104 lm/W
- Colour Rendering Index min.: 80
- Correlated colour temperature*: 3000-4000 Kelvin
- Chromaticity tolerance (initial MacAdam): 4
- Rated median useful life*:
L80 50000 h at 25 °C
- Ballast: 1x LED_Con
- Luminaire input power*: 11.5 W Power factor = 0.83
- Dimming: Fixed output
- Maintenance category CIE 97: E - Dust-proof IP5X
- Total harmonic distortion (THD): 25.00 %

This product contains a light source of energy efficiency class D.

All values marked with an * are rated values. Connected electrical load and luminous flux are subject to an initial tolerance of +/- 10%, the most similar colour temperature is subject to an initial tolerance of +/- 150K. Unless stated otherwise, the values apply to an ambient temperature of 25°C.