

Safety Information

Electrical equipment should be installed, operated, serviced, and maintained only by qualified personnel. No responsibility is assumed by Schneider Electric for any consequences arising out of the use of this material.



Esmi Impresia Red VAD Wall Mounted Sounder

Esmi Impresia Red VAD Wall Mounted Sounder (FFS06741012) is an addressable wall mounted sounder and strobe with a built-in isolator, designed for installing in addressable fire alarm systems with Esmi ELC loop controller supporting Schneider Electric communication protocol. The sounder is compatible with fire bases Esmi Impresia Standard Base (FFS06741018) for ceiling or wall mounting and Esmi Impresia Red IP65 Deep Base (FFS06741013) for wall mounting. EN 54-3 approved and for indoor and outdoor use.

The address setting is done by the panel, QR code or handheld addressing device. The address range is 1-250.

For more technical information visit www.se.com.

Installation Instructions

Note: Collect the QR code stickers from the devices if QR codes are used for addressing of the devices.

1. Follow the applicable local and national installation codes and regulations. Choose the proper place for installation of the device.
2. Turn power off the loop circuit before installing the mounted sounder.
3. Set the module address using programmer or directly from addressable fire panel.
4. Mount the fire base on the ceiling or on the wall of the protected premises using fixings according the mounting surface.
5. Connect the base to the fire panel using the wiring diagram.
6. Insert the device into the base and rotate clockwise until it drops into place - the short mark on the base fits with that on the sounder body. Continue to rotate the sounder until its mark coincides with the long mark on the base - a click is heard.
7. Program the device parameters.
8. Test the sounder for proper operation.

A-weighted sound level diagram

Angle	Sound Level (dB)
15°	88dB
45°	91dB
75°	97dB
105°	96dB
135°	89dB
165°	87dB

Installation

- IP21C (EN54-3)*
- IP65 (EN60529)**
- 10°C ÷ +50°C
- ~183g

Indoor use*
Outdoor use**

* When used with Esmi Impresia Standard Base
** When used with Esmi Impresia IP65 Red Deep Base

Visual Alarm Device (VAD) EN54-23

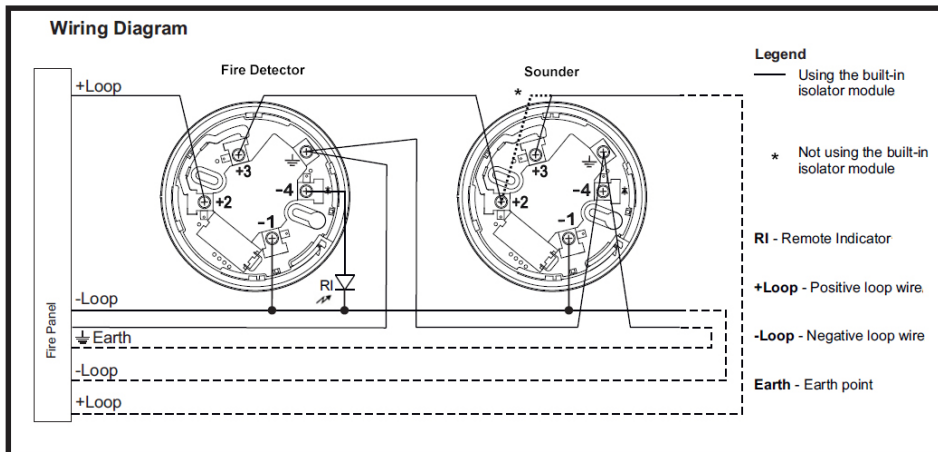
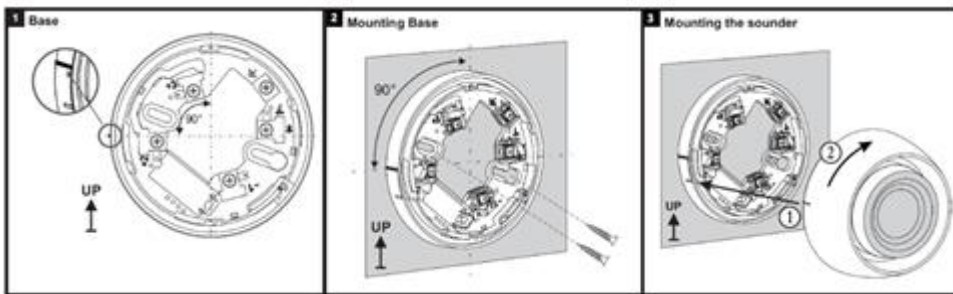

CE 21
1293

DOP: DP20028
Made in Bulgaria

EN 54-3:2001
EN 54-3:2001/A1:2002
EN 54-3:2001/A2:2006
EN 54-17:2005
EN 54-17:2005/AC:2007
EN 54-23:2010

Fire alarm devices - Visual alarm device (VAD) intended for use in and around buildings
Sounder Type: A
Coverage volume: Open class

Isolator Module Technical Specifications

Maximum line voltage (*Vmax*) 32V
 Nominal line voltage (*Vnom*) 28V
 Minimum line voltage (*Vmin*) 16V
 Maximum voltage at which the device isolates (*Vso max*)* 7.5V
 Minimum voltage at which the device isolates (*Vso min*)* 5.9V
 Maximum voltage at which the device reconnects (*Vsc max*)** 6.7V
 Minimum voltage at which the device reconnects (*Vsc min*)** 5V
 Maximum rated continuous current with the switch closed (*Ic max*) 0.7A
 Maximum rated switching current (e.g. under short circuit) (*Is max*) 1.8A
 Maximum leakage current with the switch open (isolated state) (*Ii max*) 16mA
 Maximum series impedance with the switch closed (*Zc max*)
 0.12Ω@28VDC and 0.15Ω@16VDC

* Note: Switches from closed to open
 ** Note: Switches from open to closed

Essential characteristics	Performance
Performance under fire conditions	Pass
Operational reliability	Pass
Duration of operation	Pass
Provision for external conductors	Pass
Flammability of materials	Pass
Enclosure protection	Pass
Access	Pass
Manufacturer's adjustments	Pass
On-site adjustments of behavior	Pass
Requirements for software controlled devices	Pass
Coverage volume	Pass
Variation of light output	Pass
Min. and max. light intensity	Pass
Light color	White
Light temporal pattern/ frequency of flashing	Pass
Marking and data	Pass
Synchronization	Pass
Durability:	
Temperature resistance	Pass
Humidity resistance	Pass
Shock and vibration resistance	Pass
Corrosion resistance	Pass
Resistance to ingress	Pass
Electrical stability	Pass

Technical Specifications

Operating Voltage Range 16 - 32VDC (Nom. 27VDC)
 Nominal consumption (stand-by) <500µA@27VDC
 Maximal consumption (main tone type 27):
 - low volume level, sound only <5mA
 - low volume level, sound and strobe <12mA
 - high volume level, sound only* <16.5mA
 - high volume level, sound and strobe* <22mA
 Maximal consumption (other tone types):
 - low volume level, sound only <4mA
 - low volume level, sound and strobe <11mA
 - high volume level, sound only <10mA
 - high volume level, sound and strobe <16.5mA
 Consumption with activated isolator <15mA
 Power volume (main tone type 27):
 - low volume 80dB (A) ± 6dB @ 1m
 - high volume* 92dB (A) ± 5dB @ 1m
 Power volume (other tone types):
 - low volume 75-85dB ± 3dB @ 1m
 - high volume 80-95dB ± 3dB @ 1m
 Number of tone types 32
 Wire Gauge for terminals 2.5mm²
 Relative humidity resistance (93 ± 3)% @ 40°C
 Color white transparent
 Material SAN
 Dimensions 116x55mm
 Supported communication protocol Esmi ELC

* Note: Approved to EN54-3 only!

Tone	Tone Type	Tone Description/Application
1		970Hz
2		800Hz/970Hz @ 2Hz
3		800Hz - 970Hz @ 1Hz
4		970Hz 1s OFF/1s ON
5		970Hz, 0.5s/ 630Hz, 0.5s
6		554Hz, 0.1s/ 440Hz, 0.4s (AFNOR NF S 32 001)
7		500 - 1200Hz, 3.5s/ 0.5s OFF (NEN 2575:2000)
8		420Hz 0.625s ON/0.625s OFF (Australia AS1670 Alert tone)
9		500 - 1200Hz, 0.5s/ 0.5s OFF x 3/1.5s OFF (AS1670 Evacuation)
10		550Hz/440Hz @ 0.5Hz
11		970Hz, 0.5s ON/0.5s OFF x 3/ 1.5s OFF (ISO 8201)
12		2850Hz, 0.5s ON/0.5s OFF x 3/1.5s OFF (ISO 8201)
13		1200Hz - 500Hz @ 1Hz (DIN 33 404)
14		400Hz
15		550Hz, 0.7s/1000Hz, 0.33s
16		1500Hz - 2700Hz @ 3Hz
17		750Hz
18		2400Hz
19		660Hz
20		660Hz 1.8s ON/1.8s OFF
21		660Hz 0.15s ON/0.15s OFF
22		510Hz, 0.25s/ 610Hz, 0.25s
23		800/1000Hz 0.5s each (1Hz)
24		250Hz - 1200Hz @ 12Hz
25		500Hz - 1200Hz @ 0.33Hz
26		2400Hz - 2900Hz @ 9Hz
27*		2400Hz - 2900Hz @ 3Hz 2500Hz (main sound frequency)
28		800Hz - 970Hz @ 100Hz
29		800Hz - 970Hz @ 9Hz
30		800Hz - 970Hz @ 3Hz
31		800Hz, 0.25s ON/1s OFF
32		600Hz - 1100Hz, 2.6s/0.4s OFF

* Note: Approved to EN 54-3 only!