

# Multi-function Compact Inverter M1 Series

CSM\_M1\_DS\_E\_3\_1

## Advanced position control and EtherCAT® connectivity maximize potential of your motion system

- Nine types of motor control methods
- High starting torque: 200% at 0 Hz  
(vector control with speed sensor)
- Maximum output frequency: 590 Hz
- Dual rating: Heavy load mode (1 min at 150%, 0.5 s at 200%)  
and light load mode (1 min at 120%)
- Supports induction and PM motors (up to 128 poles)
- Position control (built-in ABZ phase encoder input)
- Torque control (in vector control)
- Safety functionality: STO (Cat. 3/PLe according to ISO 13849-1)
- Two safety inputs + EDM output as standard
- Configuration using integrated development environment Sysmac Studio
- Built-in EtherCAT communications (3G3M1-□□□□□-ECT)



# M1 Series

## Standard Specifications

### Inverter 3G3M1

#### Three-phase 200-V Class

HHD: Heavy load, HND: Light load

Item		Three-phase 200 V												
Model (3G3M1-A2□□□(-ECT))		001	002	004	007	015	022	037	055	075	110	150	185	
Maximum applicable motor capacity *1	kW	HHD	0.1	0.2	0.4	0.75	1.5	2.2	3.7	5.5	7.5	11	15	18.5
		HND	0.2	0.4	0.75	1.1	2.2	3 *7	5.5 *7	7.5	11	15	18.5	22
	HP	HHD	1/8	1/4	1/2	1	2	3	5	7 1/2	10	15	20	25
		HND	1/4	1/2	1	1 1/2	3	4	7 1/2	10	15	20	25	30
Rated output capacity [kVA] *2	200 V	HHD	0.3	0.6	1	1.7	2.8	3.8	6.1	8.7	11	16	21	26
		HND	0.5	0.7	1.2	2.1	3.3	4.2	6.8	10	14	19	24	30
	240 V	HHD	0.4	0.7	1.2	2.1	3.3	4.6	7.3	10	14	20	25	32
		HND	0.5	0.8	1.5	2.5	4.0	5.0	8.1	12	17	23	29	37
Rated input voltage *3		Three-phase 200 to 240 V, 50/60 Hz												
Rated input current [A] *4	HHD	1.1	1.8	3.1	5.3	9.5	13.2	22.2	31.5	42.7	60.7	80	97	
	HND	1.8	2.6	4.9	6.7	12.8	17.9	28.5	42.7	60.7	80	97	112	
Rated output voltage		Three-phase 200 to 240 V (with AVR)												
Rated output current [A] *5	HHD	1	1.6	3	5	8	11	17.5	25	33	47	60	76	
	HND	1.3	2	3.5	6	9.6	12 *7	19.6 *7	30	40	56	69	88	
Braking torque [%] *6	HHD	150		100		70	40		20					
	HND	75	53	68	48	29 *7	27 *7	15						
Braking resistor circuit	Regenerative braking	Built-in braking resistor circuit (discharge resistor separately mounted)												
	Minimum connection resistance [Ω]	100 to 120			40 to 120		33 to 120	20 min.	15 min.	10 min.	8.6 min.	4 min.		
Short circuit current rating [kA]		100												
Weight [kg]		Approx. 0.5	Approx. 0.5	Approx. 0.7	Approx. 0.9	Approx. 1.4	Approx. 1.4	Approx. 1.7	Approx. 3.8	Approx. 4	Approx. 5.3	Approx. 5.4	Approx. 11	
Dimensions (Width × Height) [mm]		68 × 127			110 × 130			140 × 130	180 × 220		220 × 260		250 × 400	
Dimensions (Depth) [mm]		98	113	145	156			171	203		STD: 203 ECT: 208			

\*1. The maximum applicable motor capacity is given for a standard four-phase motor. When selecting an inverter, select not just by kW but also ensure that the inverter rated output current is greater than the motor rated current.

\*2. In calculating the rated capacity, the rated output voltage is assumed to be 200 V or 240 V.

\*3. A voltage higher than the power supply voltage cannot be output.

\*4. When Carrier Frequency (F26) is set to the following or below, derating is required.

HHD mode...A2001 to A2037: 8 kHz, A2055 to A2185: 10 kHz

HND mode...A2001 to A2037: 4 kHz, A2055 to A2150: 10 kHz, A2185: 4 kHz

Refer to the *Multi-function Compact Inverter M1 Series Standard Type User's Manual* (Cat. No. I669) or the *Multi-function Compact Inverter M1 Series Built-in EtherCAT® Communications Type User's Manual* (Cat. No. I670) for details.

\*5. The following shows the calculated value when the power supply capacity is 500 kVA (10x the inverter capacity when the inverter capacity exceeds 50 kVA) and when a %X = 5% power supply is connected.

\*6. The numeric value is the average braking torque per individual motor. (Varies according to motor efficiency)

\*7. Allowable ambient temperature of 40°C or below of A2022 to A2037 in the HND mode. The rated output current in the HND mode decreases by 1% for every temperature increase of 1°C when the ambient temperature is 40°C or more.

## Three-phase 400-V Class

HHD/HD: Heavy load, HND/ND: Light load

Item		Three-phase 400 V												
Model (3G3M1-A4□□□(-ECT))		004	007	015	022	030	040	055	075	110	150	185	220	
Maximum applicable motor capacity *1	kW	HD	0.75	1.1	2.2	3	4	5.5	7.5	11	15	18.5	22	30
		ND	0.75	1.5	2.2	3	4	5.5	11	15	18.5	22	30	37
		HHD	0.4	0.75	1.5	2.2	3	4	5.5	7.5	11	15	18.5	22
		HND	0.75	1.1	2.2	3 *7	4	5.5 *7	7.5	11	15	18.5	22	30
	HP	HD	1	1 1/2	3	4	5	7 1/2	10	15	20	25	30	40
		ND	1	1 1/2	3	4	5	7 1/2	15	20	25	30	40	50
		HHD	1/2	1	1 1/2	3	4	5	7 1/2	10	15	20	25	30
		HND	1	1 1/2	3	4	5	7 1/2	10	15	20	25	30	40
Rated output capacity [kVA] *2	380 V	HD	1.2	2.2	3.3	4.1	5.8	7.3	12	15	20	25	30	39
		ND	1.4	2.7	3.6	4.5	6.1	7.9	14	19	24	29	39	47
		HHD	1.2	2.2	3.2	3.6	4.7	6.1	9.7	12	16	20	26	30
		HND	1.4	2.7	3.6	4.5	5.8	7.3	12	15	20	25	30	39
	480 V	HD	1.5	2.8	4.2	5.2	7.3	9.2	15	19	26	32	37	50
		ND	1.7	3.4	4.6	5.7	7.6	10	18	24	31	37	49	60
		HHD	1.5	2.8	4	4.6	6	7.6	12.3	15	20	26	32	37
		HND	1.7	3.4	4.6	5.7	7.3	9.2	15	19	26	32	37	50
Rated input voltage *3		Three-phase 380 to 480 V, 50/60 Hz												
Rated input current [A] *4	HD	2.7	3.9	7.3	11.3	14.2	16.8	23.2	33	43.8	52.3	60.6	77.9	
	ND	2.7	4.8	7.3	11.3	14.2	16.8	33	43.8	52.3	60.6	77.9	94.3	
	HHD	1.7	3.1	5.9	8.2	11.3	14.2	17.3	23.2	33	43.8	52.3	60.6	
	HND	2.7	3.9	7.3	11.3	14.2	16.8	23.2	33	43.8	52.3	60.6	77.9	
Rated output voltage		Three-phase 380 to 480 V (with AVR)												
Rated output current [A] *5	HD	1.8	3.4	5	6.3	8.8	11.1	17.5	23	31	38	45	60	
	ND	2.1	4.1	5.5	6.9	9.2	12	21.5	28.5	37	44	59	72	
	HHD	1.8	3.4	4.8	5.5	7.2	9.2	14.8	18	24	31	39	45	
	HND	2.1	4.1	5.5	6.9 *7	8.8	11.1 *7	17.5	23	31	38	45	60	
Braking torque [%] *6	HD	53.3	68.2	47.7	29.3	29.3	26.9	15						
	ND	53.3	50.0	47.7	29.3	29.3	26.9	12						
	HHD	100		70	40	40	40	20						
	HND	53	68	48	29 *7	29	27 *7	15						
Braking resistor circuit	Regenerative braking	Built-in braking resistor circuit (discharge resistor separately mounted)												
	Minimum connection resistance [Ω]	200		160 to 200		130 to 200		80 min.	60 min.	40 min.	34.4 min.	16 min.		
Short circuit current rating [kA]		100												
Weight [kg]		Approx. 1.2	Approx. 1.4	Approx. 1.5	Approx. 1.4	Approx. 1.8	Approx. 1.8	Approx. 3.8	Approx. 3.8	Approx. 5.3	Approx. 5.4	Approx. 11	Approx. 11	
Dimensions (Width × Height) [mm]		110 × 130				140 × 130		180 × 220		220 × 260		250 × 400		
Dimensions (Depth) [mm]		132	156				171		203		STD: 203 ECT: 208			

\*1. The maximum applicable motor capacity is given for a standard four-phase motor. When selecting an inverter, select not just by kW but also ensure that the inverter rated output current is greater than the motor rated current.

\*2. In calculating the rated capacity, the rated output voltage is assumed to be 380 V or 480 V.

\*3. A voltage higher than the power supply voltage cannot be output.

\*4. When Carrier Frequency (F26) is set to the following or below, derating is required.

HHD mode...A4004 to A4040: 8 kHz, A4055 to A4220: 10 kHz

HND mode...A4004 to A4040: 8 kHz, A4055 to A4185: 10 kHz, A4220: 6 kHz

HD and ND...modes All models: 4 kHz

Refer to the *Multi-function Compact Inverter M1 Series Standard Type User's Manual* (Cat. No. I669) or the *Multi-function Compact Inverter M1 Series Built-in EtherCAT® Communications Type User's Manual* (Cat. No. I670) for details.

\*5. The following shows the calculated value when the power supply capacity is 500 kVA (10x the inverter capacity when the inverter capacity exceeds 50 kVA) and when a %X = 5% power supply is connected.

\*6. The numeric value is the average braking torque per individual motor. (Varies according to motor efficiency)

\*7. Allowable ambient temperature of 40°C or below of A4022 to A4040 in the HND mode. The rated output current of A4022 and A4040 in the HND mode decreases by 1% for every temperature increase of 1°C when the ambient temperature is 40°C or more.

# M1 Series

## Single-phase 200-V Class

HHD: Heavy load, HND: Light load

Item			Single-phase 200 V						
Model (3G3M1-AB□□□(-ECT))			001	002	004	007	015	022	037
Maximum applicable motor capacity *1	kW	HHD	0.1	0.2	0.4	0.75	1.5	2.2	3.7
		HND	0.2	0.4	0.55	1.1	2 *8	2.7 *9	---
	HP	HHD	1/8	1/4	1/2	1	2	3	5
		HND	1/4	1/2	3/4	1 1/2	3	4	---
Rated output capacity [kVA] *2	200 V	HHD	0.3	0.6	1	1.7	2.8	3.8	6.1
		HND	0.4	0.7	1.2	2.1	3.3	4.2	---
	240 V	HHD	0.4	0.7	1.2	2.1	3.3	4.6	7.3
		HND	0.5	0.8	1.5	2.5	4	5	---
Rated input voltage *3			Three-phase 200 to 240 V, 50/60 Hz						
Rated input current [A] *4	HHD		1.8	3.3	5.4	9.7	16.4	22	45.4
	HND		3.3	4.9	7.3	13.8	20.2	26	---
Rated output voltage			Three-phase 200 to 240 V (with AVR)						
Rated output current [A] *5	HHD		1	1.6	3	5	8	11	17.5
	HND		1.2	1.9	3.5 *7	6.0 *7	9.6 *7	12 *7	---
Braking torque [%] *6	HHD		150		100		70	40	40
	HND		75	73	68	48	29	---	
Braking resistor circuit	Regenerative braking		Built-in braking resistor circuit (discharge resistor separately mounted)						
	Minimum connection resistance [Ω]		100 to 120				40 to 120		
Short circuit current rating [kA]			100						
Weight [kg]			Approx. 0.5	Approx. 0.5	Approx. 0.7	Approx. 0.9	Approx. 1.5	Approx. 1.7	Approx. 3.8
Dimensions (Width × Height) [mm]			68 × 127				110 × 130	140 × 130	180 × 220
Dimensions (Depth) [mm]			98	120	165	166	156	171	

\*1. The maximum applicable motor capacity is given for a standard four-phase motor. When selecting an inverter, select not just by kW but also ensure that the inverter rated output current is greater than the motor rated current.

\*2. In calculating the rated capacity, the rated output voltage is assumed to be 200 V or 240 V.

\*3. A voltage higher than the power supply voltage cannot be output.

\*4. When Carrier Frequency (F26) is set to the following or below, derating is required.

HHD mode...AB001 to A2037: 8 kHz

HND mode...AB001 to A2022: 4 kHz

Refer to the *Multi-function Compact Inverter M1 Series Standard Type User's Manual* (Cat. No. I669) or the *Multi-function Compact Inverter M1 Series Built-in EtherCAT® Communications Type User's Manual* (Cat. No. I670) for details.

\*5. The following shows the calculated value when the power supply capacity is 500 kVA (10x the inverter capacity when the inverter capacity exceeds 50 kVA) and when a %X = 5% power supply is connected.

\*6. The numeric value is the average braking torque per individual motor. (Varies according to motor efficiency)

\*7. Allowable ambient temperature of 40°C or below of AB004, AB007, AB015 and AB022. The rated output current in the HND mode decreases by 2% for every temperature increase of 1°C when the ambient temperature is 40°C or more.

\*8. The maximum applicable motor capacity is 2.2 kW when the input voltage is 220 to 240 V.

\*9. The maximum applicable motor capacity is 3.0 kW when the input voltage is 220 to 240 V.

## Common Specifications

## Inverter 3G3M1

Item	Specifications	
Enclosure rating *1	Open type (IP20)	
Control	Control method	Phase-to-phase sinusoidal modulation PWM
	Output frequency range *2	0.00 to 590 Hz
	Frequency precision	Digital command: $\pm 0.01\%$ of the maximum frequency, Analog command: $\pm 0.2\%$ of the maximum frequency ( $25\pm 10^{\circ}\text{C}$ )
	Frequency setting resolution	Digital setting: 0.01 Hz, Analog setting: Maximum frequency $\times 5/10,000$
	Overload current rating of inverter	Heavy load rating (HHD): 150%/60 s or 200%/0.5 s Heavy load rating (HD): 150%/60 s Light load rating (HND/ND): 120%/60 s
	Instantaneous overcurrent protection	<ul style="list-style-type: none"> <li>Digital setting: 0.01 Hz (99.99 Hz max.), 0.1 Hz (100.0 to 590.0 Hz)</li> <li>Analog setting: Maximum frequency <math>\times 5/10,000</math></li> <li>Communication setting: 0.005% of the maximum output frequency or 0.01 Hz (fixed)</li> </ul>
	Acceleration/Deceleration time	0.00 to 6000 s (line/curve arbitrary setting), 2nd acceleration/deceleration setting provided
	Carrier frequency change range	<p>Three-phase 400-V class</p> <ul style="list-style-type: none"> <li>3G3M1-A4004 to A4185 0.75 to 16 kHz (HHD/HND/HD) 0.75 to 10 kHz (ND)</li> <li>3G3M1-A4220 0.75 to 16 kHz (HHD) 0.75 to 10 kHz (HND/HD) 0.75 to 6 kHz (ND)</li> </ul> <p>Three-phase 200-V class</p> <ul style="list-style-type: none"> <li>3G3M1-A2001 to A2015, A2055 to A2185 0.75 to 16 kHz (HHD/HND)</li> <li>3G3M1-A2022/A2037 0.75 to 16 kHz (HHD) 0.75 to 10 kHz (HND)</li> </ul> <p>Single-phase 200-V class</p> <ul style="list-style-type: none"> <li>3G3M1-AB001 to AB022 0.75 to 16 kHz (HHD) 0.75 to 10 kHz (HND)</li> <li>3G3M1-AB037 0.75 to 16 kHz (HHD)</li> </ul> <p>The carrier frequency automatically drops according to the ambient temperature and output current. (This function can be disabled.)</p>
	Starting torque	<ul style="list-style-type: none"> <li>150% min. / Rated speed of 10% V/f control (IM motor) V/f control (slip compensation) V/f control with speed sensor (IM motor)</li> <li>200% min./0.5 Hz Vector control without speed sensor (dynamic vector control) (IM motor) V/f control with speed feedback (Automatic torque boost) Sensorless vector control</li> <li>200% min./0.0 Hz (0 Hz torque control) Vector control with speed sensor (IM motor) Vector control with speed and pole position sensor (PM motor) To obtain 200% starting torque at low speed, consider raising the capacity of the inverter to the next higher capacity.</li> <li>200% min. / Rated speed of 10% Vector control without speed and pole position sensor (PM motor) To obtain these starting torques at low speed, the capacity of the inverter and motor must be taken into consideration.</li> </ul> <p>The maximum torque that can be used is limited when the current capacity matched to the mode is exceeded. Current capacity of 200% in HHD mode, 150% in HD mode, and 120% in HND and ND modes</p>

# M1 Series

Item		Specifications											
<b>Protective function</b>		Overcurrent, Overvoltage, Undervoltage, Electronic thermal, Temperature error, Ground-fault current at power-on, Inrush current prevention circuit, Overload limit, Incoming overvoltage, External trip, Memory error, CPU error, USP error, Communication error, Overvoltage suppression during deceleration, Power interruption protection, Emergency Forced Stop, etc.											
<b>Input signal</b>	<b>Frequency settings</b>	<ul style="list-style-type: none"> <li>Standard Type 3G3M1-□□□□□□: Operator External analog input signal (variable resistor/0 to 10 VDC/-10 to 10 VDC/4 to 20 mA), Modbus communication</li> <li>Built-in EtherCAT Communications Type 3G3M1-□□□□□-ECT: External analog input signal (variable resistor/0 to 10 VDC)</li> </ul>											
	<b>RUN/STOP command</b>	<ul style="list-style-type: none"> <li>Standard Type 3G3M1-□□□□□□: Operator External digital input signal (3-wire input available), Modbus communication</li> <li>Built-in EtherCAT Communications Type 3G3M1-□□□□□□-ECT: External digital input signal (3-wire input available)</li> </ul>											
	<b>Multi-function Input *3</b>	Seven points (DI1 to DI7, Functions can be selected from among 101)											
	<b>Analog input *4</b>	<ul style="list-style-type: none"> <li>Standard Type 3G3M1-□□□□□□: Two points (voltage AI1 terminal: 10 bits/-10 to 10 VDC, voltage AI2 (AIV) terminal: 10 bits/0 to 10 V, current AI2 (AII) terminal: 10 bits/4 to 20 mA or 0 to 20 mA)</li> <li>Built-in EtherCAT Communications Type 3G3M1-□□□□□□-ECT: One point (voltage AI1 terminal: 10 bits/-10 to 10 VDC)</li> </ul>											
	<b>Pulse input</b>	One point (A, B, Z phases can be input, max. 32 kHz, 5 to 24 VDC)											
<b>Output signal</b>	<b>Multi-function output *3</b>	<ul style="list-style-type: none"> <li>Standard Type 3G3M1-□□□□□□: Two points (DO1 and DO2, Functions can be selected from among 92)</li> <li>Built-in EtherCAT Communications Type 3G3M1-□□□□□□-ECT: One point (DO1, Functions can be selected from among 92)</li> </ul>											
	<b>Relay output *3</b>	One point (SPDT contact (ROA, ROB, ROC), Functions can be selected from among 92)											
	<b>Analog output *5</b>	<ul style="list-style-type: none"> <li>Standard Type 3G3M1-□□□□□□ only: One point (AO (AOV) terminal: Voltage 10 bits/0 to 10 V, AO (AOI) terminal: Current 10 bits/4 to 20 mA or 0 to 20 mA, AO (PO) terminal: Max. 32 kHz, 0 to 11 V)</li> </ul>											
	<b>Pulse output</b>												
<b>Communications</b>	<b>RS-485</b>	<ul style="list-style-type: none"> <li>Standard Type 3G3M1-□□□□□□ only: RJ45 connector (for Digital Operator)</li> </ul>											
	<b>RS-485</b>	<ul style="list-style-type: none"> <li>Standard Type 3G3M1-□□□□□□ only: Control circuit terminal block, Modbus communication</li> </ul>											
	<b>USB</b>	USB 2.0, Micro-B connector											
<b>Other functions</b>		AVR function, V/f characteristics switching, Upper/Lower limit, Multi-step speed (16 steps), Starting frequency adjustment, Jogging operation, Carrier frequency adjustment, PID control, Frequency jump, Analog gain/bias adjustment, S-shape acceleration/deceleration, Electronic thermal characteristics/level adjustment, Restart function, Torque boost function, Fault monitor, Soft lock function, Frequency conversion display, USP function, 2nd control function, UP/DOWN, Overcurrent suppression function, etc.											
<b>General specifications</b>	<b>Operating ambient temperature *6</b>	-10 to 50°C (Derating required)											
	<b>Storage ambient temperature</b>	-25 to 70°C (Short-time temperature during shipment)											
	<b>Operating ambient humidity</b>	5% to 95% (with no condensation)											
	<b>Vibration resistance</b>	<table border="1"> <thead> <tr> <th>Vibration Frequency</th> <th>Specification</th> </tr> </thead> <tbody> <tr> <td>2 to less than 9 Hz</td> <td>3 mm (0.12 inch) (Max. amplitude)</td> </tr> <tr> <td>9 to less than 20 Hz</td> <td>1 G</td> </tr> <tr> <td>20 to less than 55 Hz</td> <td>0.2 G</td> </tr> <tr> <td>55 to less than 200 Hz</td> <td>0.1 G</td> </tr> </tbody> </table>		Vibration Frequency	Specification	2 to less than 9 Hz	3 mm (0.12 inch) (Max. amplitude)	9 to less than 20 Hz	1 G	20 to less than 55 Hz	0.2 G	55 to less than 200 Hz	0.1 G
		Vibration Frequency	Specification										
		2 to less than 9 Hz	3 mm (0.12 inch) (Max. amplitude)										
9 to less than 20 Hz		1 G											
20 to less than 55 Hz	0.2 G												
55 to less than 200 Hz	0.1 G												
<b>Location</b>	At a maximum altitude of 1,000 m, indoors (without corrosive gases or dust)												

\*1. The enclosure rating complies with JISC0920.

\*2. If you must use the motor at higher than 50/60 Hz, check the allowable maximum motor speed and other information with the motor manufacturer.

\*3. In the HND/ND (light load) mode or PM motor mode compared with the HHD/HD (heavy load) mode, for some parameters, the default data and setting range also differ. Refer to the *Multi-function Compact Inverter M1 Series Standard Type User's Manual* (Cat.No.I669) or the *Multi-function Compact Inverter M1 Series Built-in EtherCAT® Communications Type User's Manual* (Cat.No.I670) for details.

\*4. By default, the maximum frequency is adjusted to 10 V for a voltage input of 0 to 10 VDC and to 20 mA for a current input of 4 to 20 mA, respectively. If necessary, adjust the default parameter settings. Refer to the *Multi-function Compact Inverter M1 Series Standard Type User's Manual* (Cat.No.I669) or the *Multi-function Compact Inverter M1 Series Built-in EtherCAT® Communications Type User's Manual* (Cat.No.I670) for details.

\*5. The analog output shows values that can only be used as a guide for analog meter connection. The maximum output value may differ from 10 V or 20 mA due to the variability of the analog output circuit. If necessary, adjust the default parameter settings.

\*6. Derating of the rated output current of the inverter may be required depending on the heavy/light load mode selection, operating ambient temperature, side-by-side installation, and carrier frequency settings. Refer to the *Multi-function Compact Inverter M1 Series Standard Type User's Manual* (Cat.No.I669) or the *Multi-function Compact Inverter M1 Series Built-in EtherCAT® Communications Type User's Manual* (Cat.No.I670) for details.

## Regulations and Standards

To export (or provide to nonresident aliens) any part of this product that falls under the category of goods (or technologies) for which an export certificate or license is mandatory according to the Foreign Exchange and Foreign Trade Control Law of Japan, an export certificate or license (or service transaction approval) according to this law is required.

Standard		Applicable standard
CE UKCA	EMC	EN 61800-3:2004/A1:2012
	Functional safety	EN 61800-5-2:2017 STO SIL3 EN ISO 13849-1:2015, Cat.3 / PLe
	Electrical safety	EN 61800-5-1:2017
UL	US	UL61800-5-1, Edition 1, 2012
	CA	CSA-C22.2 No.274, 2017
KC		KS-C9800-3 (Standard Type 3G3M1-□□□□□ only)
RCM		EN 61800-3:2004+A1:2012

The customer must check the conditions that must be met for compliance with the environmental standards and regulations of their respective country.

### 1. Checking use of regulated chemical substances

This product complies with regulated substances used in electrical parts based on the RoHS Directive.

For details on the Certificate of Conformance and other regulations, contact the place of purchase.

### 2. Motor efficiency regulations

This product is subject to energy efficiency regulations when it is used in motor systems that are driven by an inverter. For details on inverter efficiency with respect to motor output in accordance with EU efficiency regulations, refer to the following website.

<https://industrial.omron.eu/en/company-info/environmental/ecodesign-directive>

## M1 Series

# EtherCAT Communications Specifications

### Inverter 3G3M1 (3G3M1-A□□□□-ECT only)

Item	Specifications
Physical layer	100BASE-TX (IEEE802.3)
Connectors	RJ45 × 2 (shielded) ECAT IN: EtherCAT input ECAT OUT: EtherCAT output
Communications media	Category 5 or higher (cable with double, aluminum tape and braided shielding) is recommended.
Communications distance	Distance between nodes: 100 m max.
Process data	Fixed PDO mapping User PDO mapping
Mailbox (CoE)	Emergency messages, SDO requests, and SDO responses
Synchronization mode	Free Run Mode *1
Indicators	L/A IN (Link/Activity IN) × 1 L/A OUT (Link/Activity OUT) × 1 RUN × 1 ERR × 1
CiA 402 Drive Profile	Velocity mode

\*1. In Free Run Mode, slaves perform I/O processing (refresh I/O data) asynchronously with the communications cycle of the master. The communications cycle is determined by the cycle time of the master. For the communications response time of the EtherCAT communication unit, refer to *the Multi-function Compact Inverter M1 Series Built-in EtherCAT® Communications Type User's Manual* (Cat. No. I670). Note that Free Run Mode in the synchronization mode has a different meaning from free-run stop of an Inverter.



## Safety Function

The safety function is designed so that the safety stop function of category 0 (uncontrolled stop) specified in IEC 60204-1 is used to meet the safety standards of PL-e under ISO 13849-1.

M1 Inverters have two type STO functions. Use either or both functions in the table below according to the model you are using.

Type	STO function by safety input signals	STO function via EtherCAT communications
Standard Type 3G3M1-□□□□□□	Yes	No
Built-in EtherCAT Communications Type 3G3M1-□□□□□□-ECT	Yes	Yes

## Safety Functions

Function	Standard
STO (Safe Torque Off)	EN IEC 61800-5-2
Stop Category 0	EN IEC 60204-1

## Response Time

Response time		Remarks
STO response time	50 ms or less	Time from when the SF1/SF2 signal state changes to STO up to when power to the motor is cut off
EDM response time	50 ms	Time from when the SF1/SF2 signal state changes to STO up to when the EDM signal state changes to ON
STO function via Ether-CAT communication response time	80 ms max.	Time from when the FSoE state changes to STO up to when power to the motor is cut off

## Safety Related Parameters

Parameter	Value	Standard
PL	e	EN ISO 13849-1 EN IEC 60204-1
Cat	3	
MTTFd	>62 years	
DCavg	Medium	

Parameter		Value	Standard
SIL		3	EN IEC 61508-1 to -7 EN IEC 61800-5-2 EN IEC 62061
HFT		1	
SFF		>90 %	
STO Function by Safety Input Signal	PFH	$3.00 \times 10^{-9}$	
	PFD	$4.00 \times 10^{-5}$	
	Mission time	20 years	
STO Function via EtherCAT Communications	PFH	$1.10 \times 10^{-8}$	
	PFD	$1.10 \times 10^{-4}$	
	Mission time	10 years	

# M1 Series

## Appearance and Part Names

### Inverter 3G3M1

3G3M1-A□□□□

The following shows the front view when the product is unpacked.

(An example of 3G3M1-AB001/AB002/AB004/AB007/A2001/A2002/A2004/A2007)

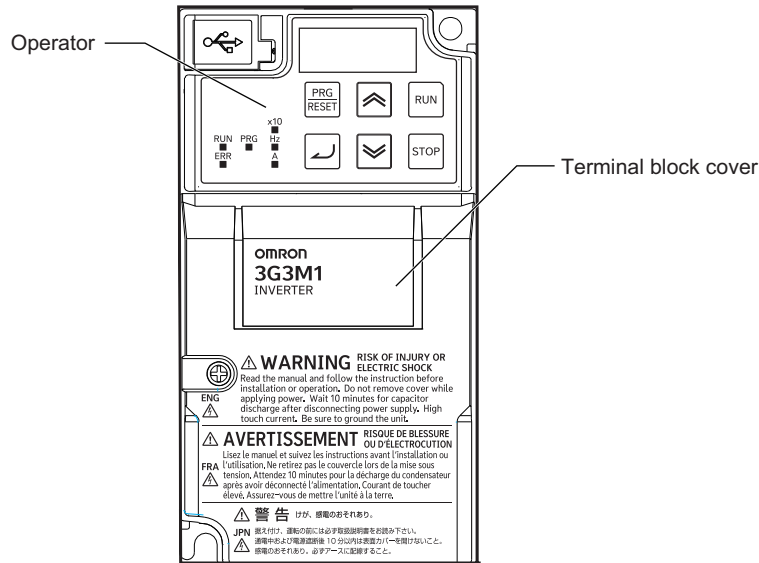

Open the terminal block cover to wire the main circuit terminal block and the control circuit terminal block.

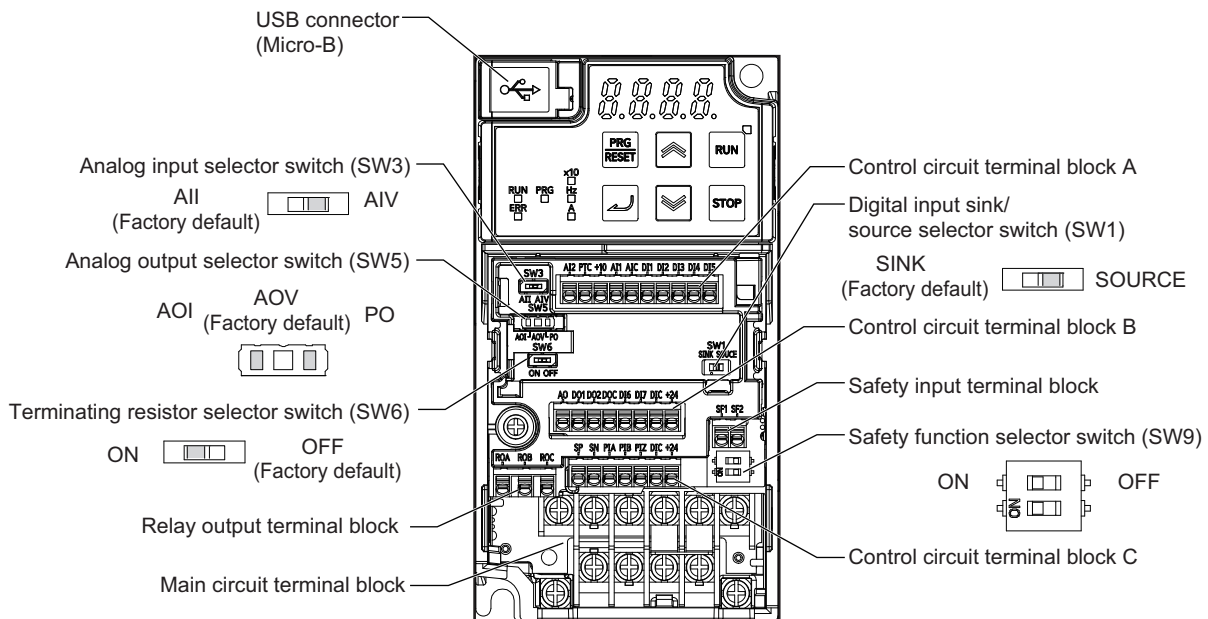

**3G3M1-A□□□□-ECT**

The following shows the front view when the product is unpacked.

(An example of 3G3M1-AB001-ECT/AB002-ECT/AB004-ECT/AB007-ECT/A2001-ECT/A2002-ECT/A2004-ECT/A2007-ECT)

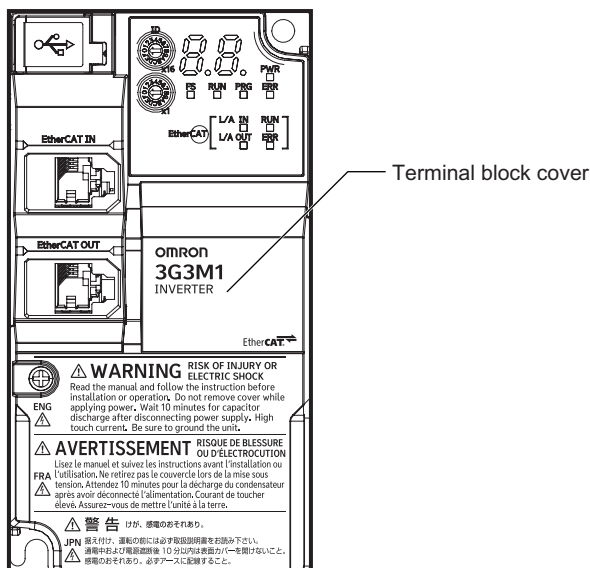

Open the terminal block cover to wire the main circuit terminal block and the control circuit terminal block.

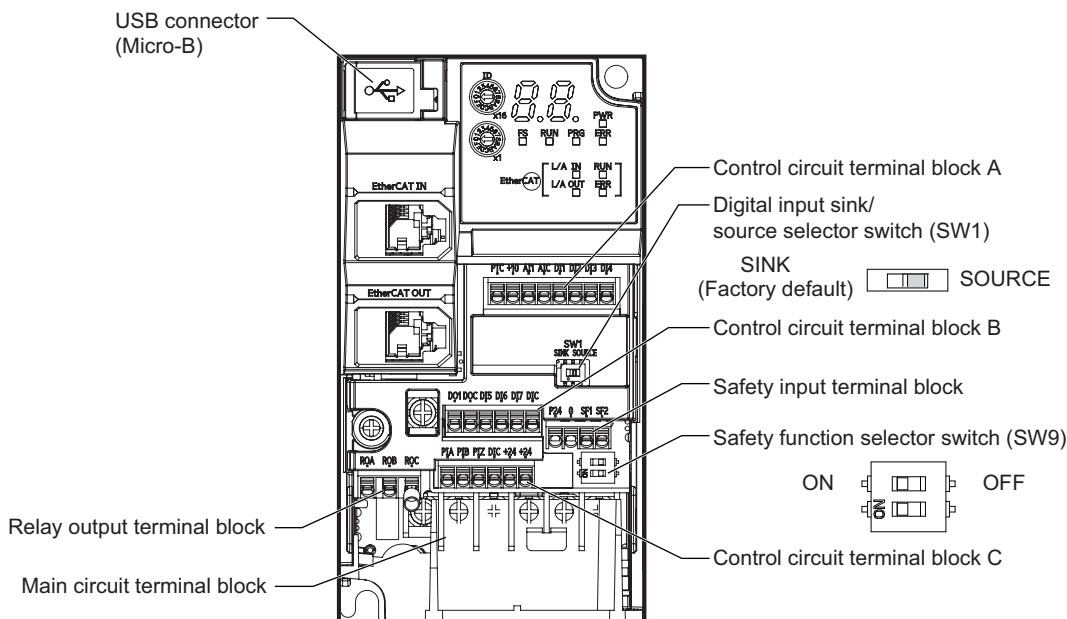

# M1 Series

## Standard Connection Diagram

### Inverter 3G3M1

3G3M1-A□□□□

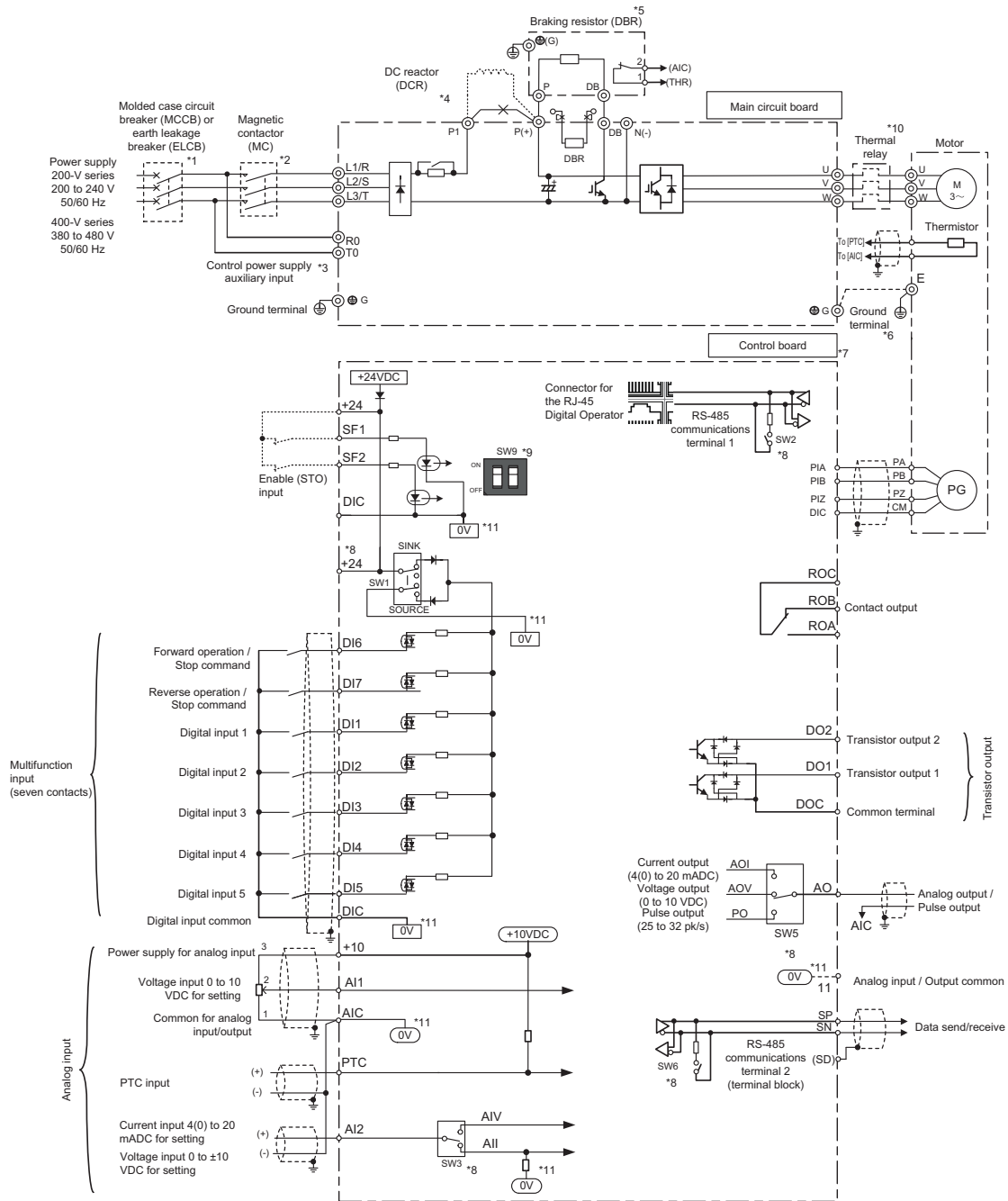

- \*1. To protect the wiring, install a molded case circuit breaker (MCCB) or earth leakage circuit breaker (ELCB) (with overcurrent protection function) recommended for each inverter on the inverter input side (primary side). Do not use circuit breakers whose rated current exceeds recommended values.
- \*2. The molded case circuit breaker and earth leakage circuit breaker are also used for insulation from the inverter's power supply. For this reason, install a magnetic contactor (MC) recommended for each inverter as required. When installing a magnetic contactor and solenoid or other coil near an inverter, connect surge absorbers in parallel.
- \*3. To enable a batch alarm signal when the protection function is activated even if the main power supply of the inverter is cut off or to display the Digital Operator at all times, connect these terminals to the power supply. (3G3M1-A2185 or later or 3G3M1-A4185 or later products) The inverter operates even when these terminals are not connected to the power supply.
- \*4. When connecting the optional DC reactor (DCR), remove the short-circuit bar between the main circuit terminals P1 and P(+) of the inverter before connecting. When the capacity of the power transformer is 500 kVA or more and 10 times or more than the rated capacity of the inverter, or when a thyristor load is connected, use a DC reactor (DCR).
- \*5. As a transistor for braking is built into the inverter, the braking resistor can be directly connected between P(+) and DB.
- \*6. The terminal for grounding the motor. Connect this terminal, as required.
- \*7. Use twisted wire or shield wire for the control signal wire.  
Generally, shield wire is grounded. However, when inductive noise from an external source is large, the influence of noise can sometimes be suppressed by connecting the shield wire to a DIC. Separate control signal wire as far as possible (at least 10 cm is recommended) from the wiring of the main circuit, and do not pass control signal wire through the same wiring duct. When wires cross, be sure to cross them so that they are almost vertical to the wiring of the main circuit.
- \*8. This switch on the printed circuit board is for specifying the operation setting of the inverter. For details, refer to *the Multi-function Compact Inverter M1 Series Standard Type User's Manual* (Cat.No.1669).
- \*9. Safety function terminals SF1 and SF2 are disabled at SW9 (double-pole switch) on the printed circuit board before shipment from the factory. When using the SF1 and SF2 terminal functions, be sure to turn each SW9 switch OFF before connecting to these terminals.
- \*10. Cut off the molded case circuit breaker (MCCB) or magnetic contactor (MC) at the auxiliary contact (manual reset) of the thermal relay.
- \*11.  $\square 0V$  and  $\circ 0V$  are separated and insulated.

3G3M1-A□□□□-ECT

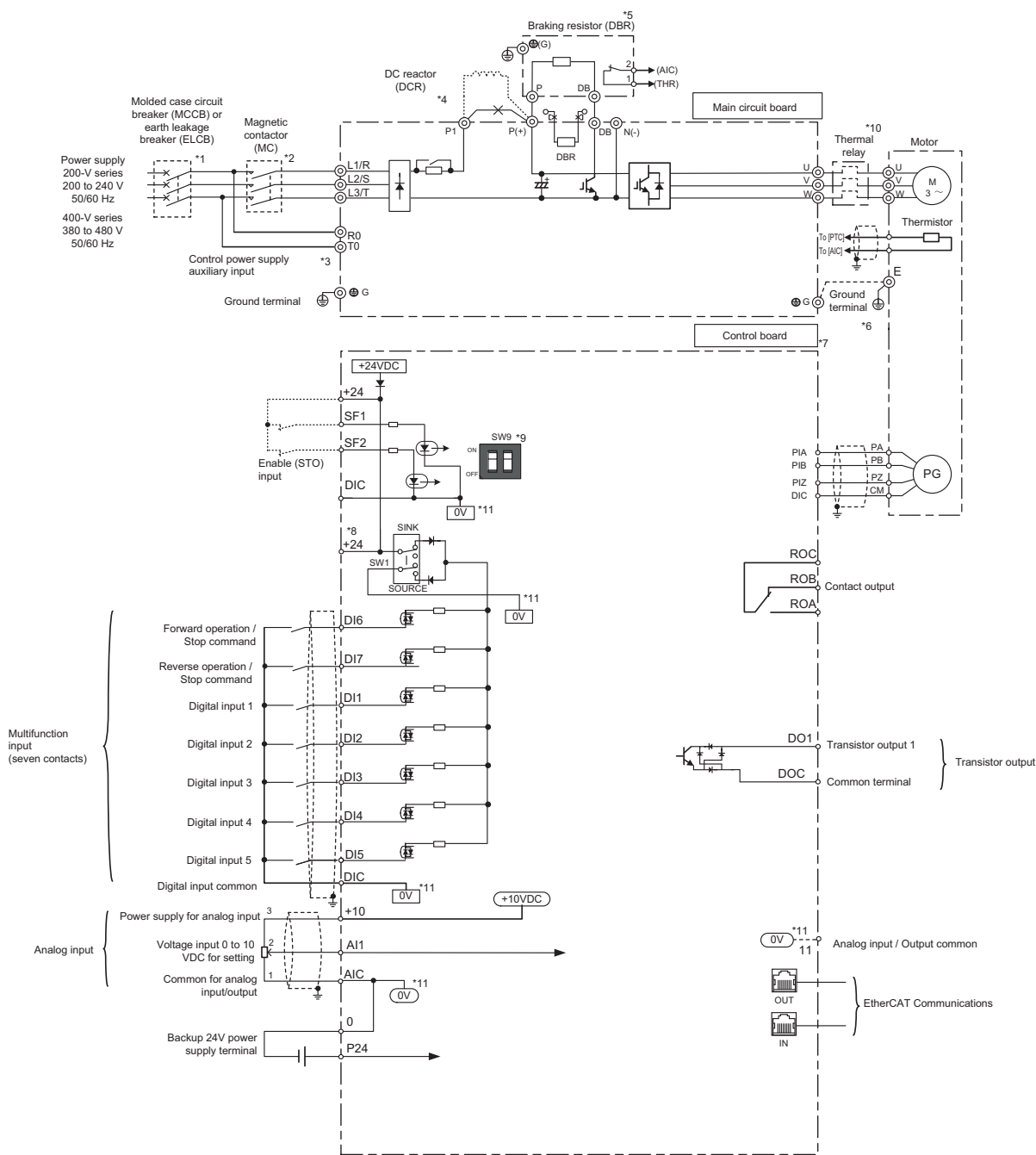

- \*1. To protect the wiring, install a molded case circuit breaker (MCCB) or earth leakage circuit breaker (ELCB) (with overcurrent protection function) recommended for each inverter on the inverter input side (primary side). Do not use circuit breakers whose rated current exceeds recommended values.
- \*2. The molded case circuit breaker and earth leakage circuit breaker are also used for insulation from the inverter's power supply. For this reason, install a magnetic contactor (MC) recommended for each inverter as required. When installing a magnetic contactor and solenoid or other coil near an inverter, connect surge absorbers in parallel.
- \*3. To enable a batch alarm signal when the protection function is activated even if the main power supply of the inverter is cut off or to display the Digital Operator at all times, connect these terminals to the power supply. (3G3M1-A2185 or later or 3G3M1-A4185 or later products) The inverter operates even when these terminals are not connected to the power supply.
- \*4. When connecting the optional DC reactor (DCR), remove the short-circuit bar between the main circuit terminals P1 and P(+) of the inverter before connecting. When the capacity of the power transformer is 500 kVA or more and 10 times or more than the rated capacity of the inverter, or when a thyristor load is connected, use a DC reactor (DCR).
- \*5. As a transistor for braking is built into the inverter, the braking resistor can be directly connected between P(+) and DB.
- \*6. The terminal for grounding the motor. Connect this terminal, as required.
- \*7. Use twisted wire or shield wire for the control signal wire. Generally, shield wire is grounded. However, when inductive noise from an external source is large, the influence of noise can sometimes be suppressed by connecting the shield wire to a DIC. Separate control signal wire as far as possible (at least 10 cm is recommended) from the wiring of the main circuit, and do not pass control signal wire through the same wiring duct. When wires cross, be sure to cross them so that they are almost vertical to the wiring of the main circuit.
- \*8. This switch on the printed circuit board is for specifying the operation setting of the inverter. For details, refer to the *Multi-function Compact Inverter M1 Series Built-in EtherCAT® Communications Type User's Manual* (Cat.No.I670).
- \*9. Safety function terminals SF1 and SF2 are disabled at SW9 (double-pole switch) on the printed circuit board before shipment from the factory. When using the SF1 and SF2 terminal functions, be sure to turn each SW9 switch OFF before connecting to these terminals.
- \*10. Cut off the molded case circuit breaker (MCCB) or magnetic contactor (MC) at the auxiliary contact (manual reset) of the thermal relay.
- \*11. 0V and 0V are separated and insulated.

# M1 Series

## Dimensions

(unit: mm)

### Inverter 3G3M1

3G3M1-A□□□□

- 3G3M1-AB001
- 3G3M1-AB002
- 3G3M1-AB004
- 3G3M1-AB007
- 3G3M1-A2001
- 3G3M1-A2002
- 3G3M1-A2004
- 3G3M1-A2007

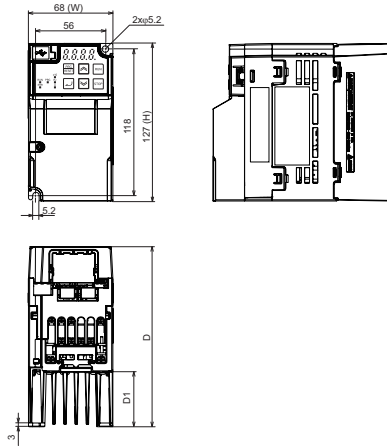

Power supply	Model	W (mm)	H (mm)	D (mm)	D1 (mm)
Single-phase 200 V	3G3M1-AB001 3G3M1-AB002	68	127	98	8
	3G3M1-AB004			120	23
	3G3M1-AB007			165	48
Three-phase 200 V	3G3M1-A2001 3G3M1-A2002	68	127	98	8
	3G3M1-A2004			113	23
	3G3M1-A2007			145	48

- 3G3M1-AB015
- 3G3M1-A2015
- 3G3M1-A2022
- 3G3M1-A4004
- 3G3M1-A4007
- 3G3M1-A4015
- 3G3M1-A4022

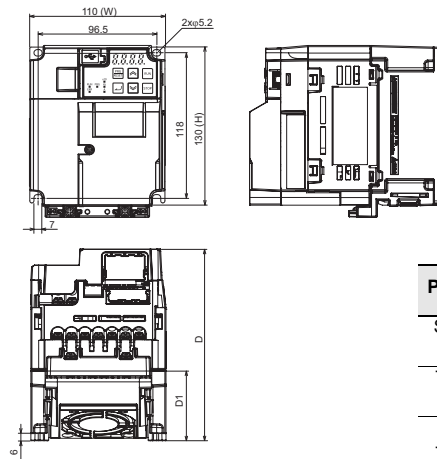

Power supply	Model	W (mm)	H (mm)	D (mm)	D1 (mm)
Single-phase 200 V	3G3M1-AB015	110	130	166	58
Three-phase 200 V	3G3M1-A2015 3G3M1-A2022			156	
	3G3M1-A4004			132	38
Three-phase 400 V	3G3M1-A4007 3G3M1-A4015 3G3M1-A4022	110	130	156	58

- 3G3M1-AB022
- 3G3M1-A2037
- 3G3M1-A4030
- 3G3M1-A4040

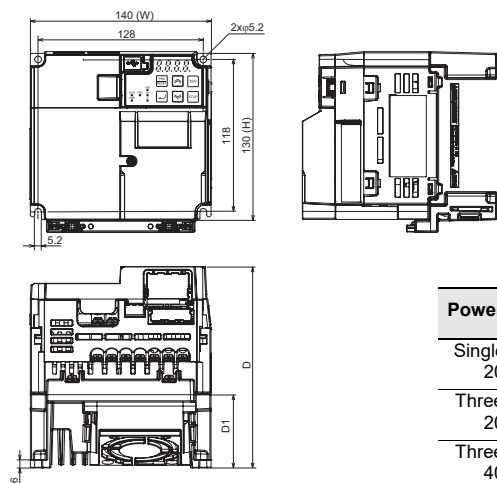

Power supply	Model	W (mm)	H (mm)	D (mm)	D1 (mm)
Single-phase 200 V	3G3M1-AB022	140	130	156	58
Three-phase 200 V	3G3M1-A2037				
Three-phase 400 V	3G3M1-A4030 3G3M1-A4040				

3G3M1-AB037  
 3G3M1-A2055  
 3G3M1-A2075  
 3G3M1-A4055  
 3G3M1-A4075

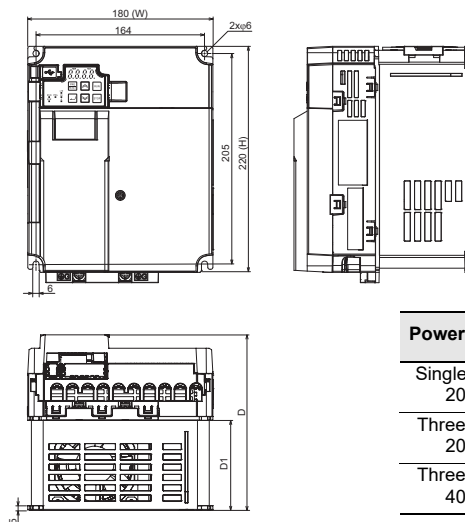

Power supply	Model	W (mm)	H (mm)	D (mm)	D1 (mm)
Single-phase 200 V	3G3M1-AB037	180	220	171	87.7
Three-phase 200 V	3G3M1-A2055				
Three-phase 200 V	3G3M1-A2075				
Three-phase 400 V	3G3M1-A4055				
	3G3M1-A4075				

3G3M1-A2110  
 3G3M1-A2150  
 3G3M1-A4110  
 3G3M1-A4150

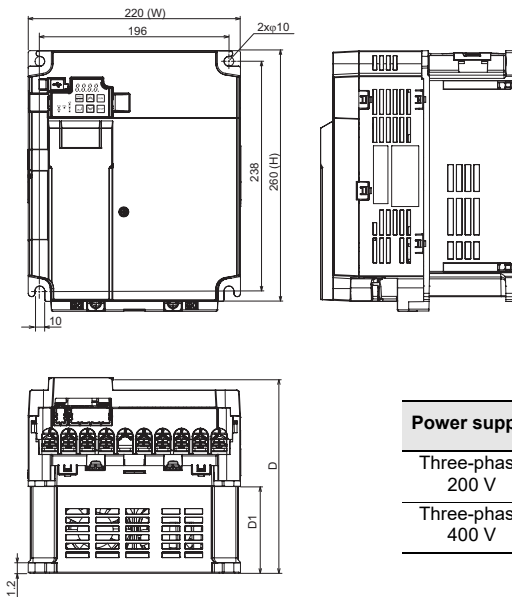

Power supply	Model	W (mm)	H (mm)	D (mm)	D1 (mm)
Three-phase 200 V	3G3M1-A2110	220	260	203	90
Three-phase 200 V	3G3M1-A2150				
Three-phase 400 V	3G3M1-A4110				
	3G3M1-A4150				

3G3M1-A2185  
 3G3M1-A4185  
 3G3M1-A4220

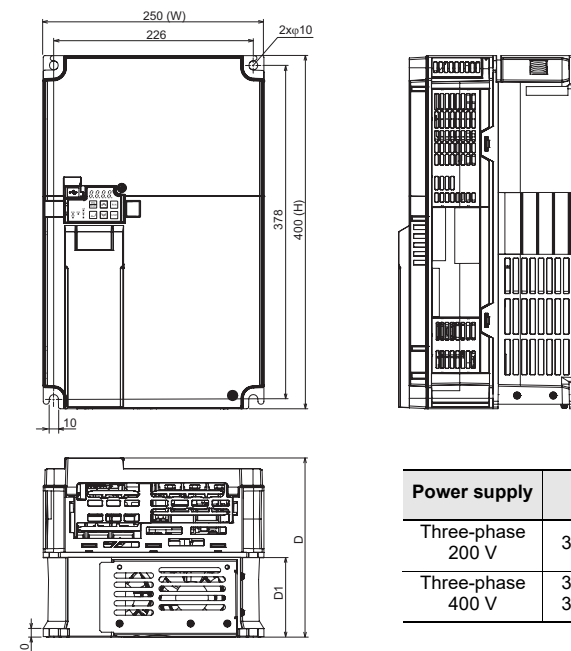

Power supply	Model	W (mm)	H (mm)	D (mm)	D1 (mm)
Three-phase 200 V	3G3M1-A2185	250	400	203	90
Three-phase 400 V	3G3M1-A4185				
Three-phase 400 V	3G3M1-A4220				

# M1 Series

## 3G3M1-A□□□□-ECT

- 3G3M1-AB001-ECT
- 3G3M1-AB002-ECT
- 3G3M1-AB004-ECT
- 3G3M1-AB007-ECT
- 3G3M1-A2001-ECT
- 3G3M1-A2002-ECT
- 3G3M1-A2004-ECT
- 3G3M1-A2007-ECT

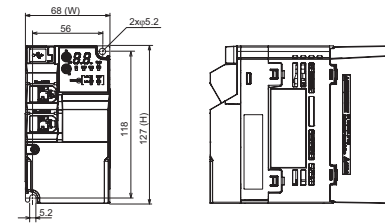

Power supply	Model	W (mm)	H (mm)	D (mm)	D1 (mm)
Single-phase 200 V	3G3M1-AB001-ECT 3G3M1-AB002-ECT	68	127	98	8
	3G3M1-AB004-ECT			120	23
	3G3M1-AB007-ECT			165	48
Three-phase 200 V	3G3M1-A2001-ECT 3G3M1-A2002-ECT			98	8
	3G3M1-A2004-ECT			113	23
	3G3M1-A2007-ECT			145	48

- 3G3M1-AB015-ECT
- 3G3M1-A2015-ECT
- 3G3M1-A2022-ECT
- 3G3M1-A4004-ECT
- 3G3M1-A4007-ECT
- 3G3M1-A4015-ECT
- 3G3M1-A4022-ECT

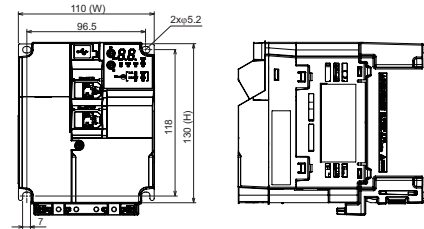

Power supply	Model	W (mm)	H (mm)	D (mm)	D1 (mm)
Single-phase 200 V	3G3M1-AB015-ECT	110	130	166	58
Three-phase 200 V	3G3M1-A2015-ECT 3G3M1-A2022-ECT			156	
	3G3M1-A4004-ECT			132	38
Three-phase 400 V	3G3M1-A4007-ECT 3G3M1-A4015-ECT 3G3M1-A4022-ECT			156	58

- 3G3M1-AB022-ECT
- 3G3M1-A2037-ECT
- 3G3M1-A4030-ECT
- 3G3M1-A4040-ECT

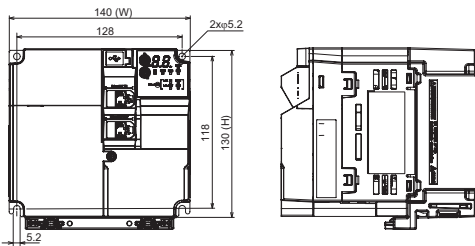

Power supply	Model	W (mm)	H (mm)	D (mm)	D1 (mm)
Single-phase 200 V	3G3M1-AB022-ECT	140	130	156	58
Three-phase 200 V	3G3M1-A2037-ECT				
Three-phase 400 V	3G3M1-A4030-ECT 3G3M1-A4040-ECT				



3G3M1-AB037-ECT  
 3G3M1-A2055-ECT  
 3G3M1-A2075-ECT  
 3G3M1-A4055-ECT  
 3G3M1-A4075-ECT

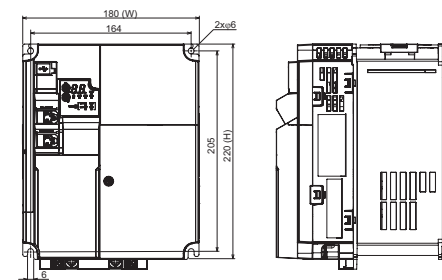

Power supply	Model	W (mm)	H (mm)	D (mm)	D1 (mm)
Single-phase 200 V	3G3M1-AB037-ECT	180	220	171	87.7
Three-phase 200 V	3G3M1-A2055-ECT 3G3M1-A2075-ECT				
Three-phase 400 V	3G3M1-A4055-ECT 3G3M1-A4075-ECT				

3G3M1-A2110-ECT  
 3G3M1-A2150-ECT  
 3G3M1-A4110-ECT  
 3G3M1-A4150-ECT

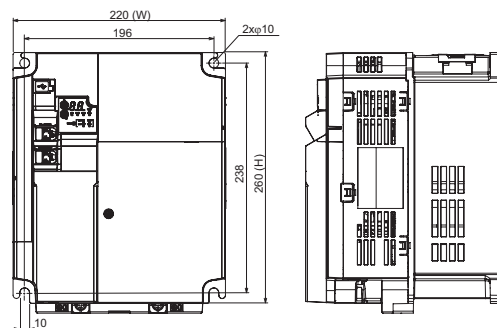

Power supply	Model	W (mm)	H (mm)	D (mm)	D1 (mm)
Three-phase 200 V	3G3M1-A2110-ECT 3G3M1-A2150-ECT	220	260	203	90
Three-phase 400 V	3G3M1-A4110-ECT 3G3M1-A4150-ECT				

3G3M1-A2185-ECT  
 3G3M1-A4185-ECT  
 3G3M1-A4220-ECT

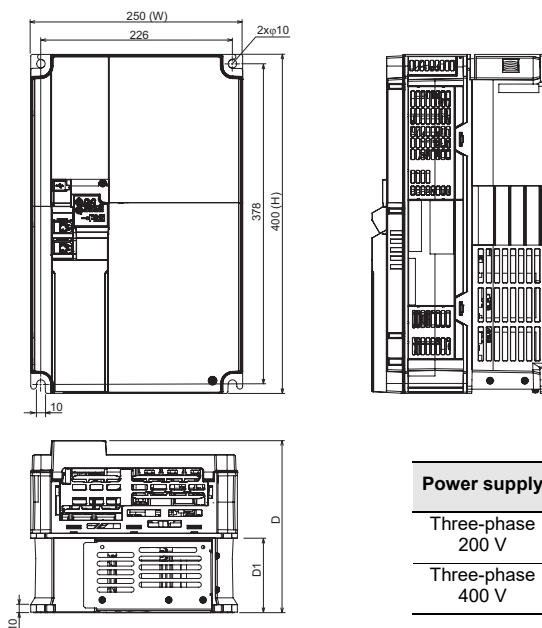

Power supply	Model	W (mm)	H (mm)	D (mm)	D1 (mm)
Three-phase 200 V	3G3M1-A2185-ECT	250	400	208	90
Three-phase 400 V	3G3M1-A4185-ECT 3G3M1-A4220-ECT				



---

# Ordering Information

---

System Configuration .....	20
Interpreting Model Numbers .....	21
Ordering Information	
M1 series Inverter Models .....	22
Recommended EtherCAT Communications Cables .....	24
Software.....	25
Related Manuals.....	26

Sysmac is a trademark or registered trademark of OMRON Corporation in Japan and other countries for OMRON factory automation products.

Windows is either registered trademarks or trademarks of Microsoft Corporation in the United States and/or other countries.

EtherCAT® and Safety over EtherCAT® are registered trademarks and patented technologies, licensed by Beckhoff Automation GmbH, Germany.

Other company names and product names in this document are the trademarks or registered trademarks of their respective companies.

The product photographs and figures that are used in this catalog may vary somewhat from the actual products.

# M1 Series

## System Configuration

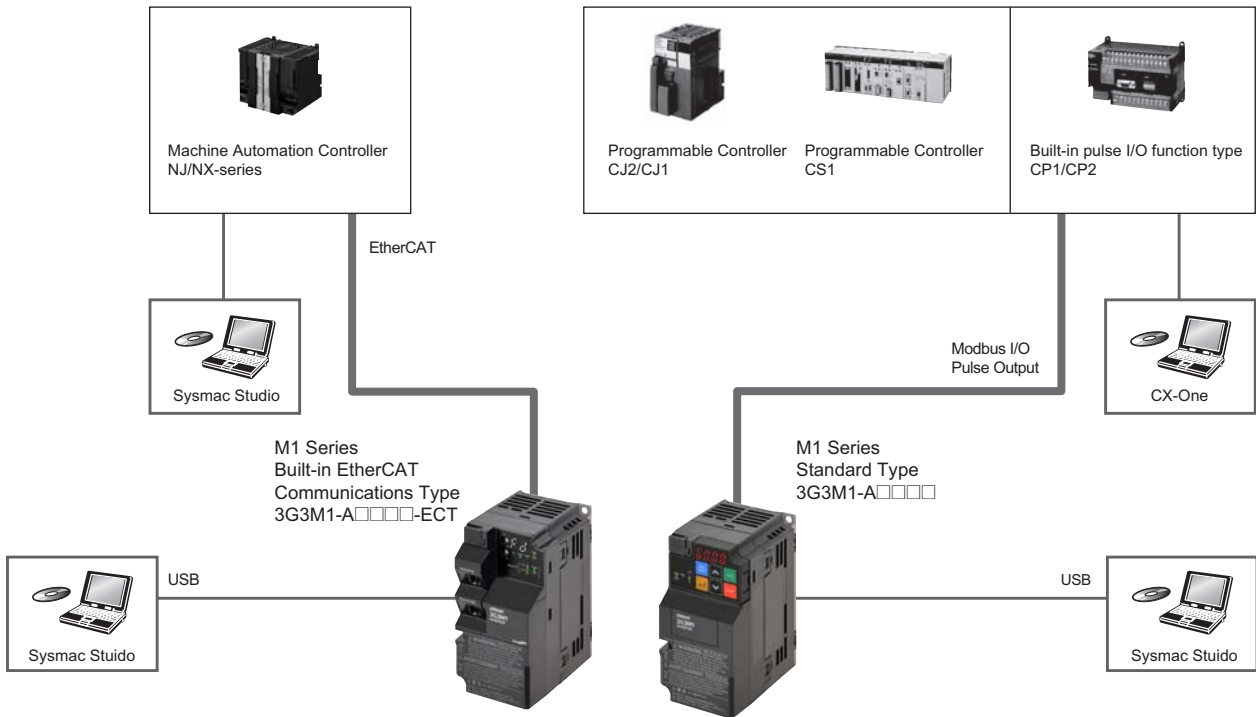

## Interpreting Model Numbers

### 3G3M1-A□□□□

3 G 3 M 1 - A 2 0 0 1

Maximum applicable motor capacity (HHD rating)

001	0.1 kW
002	0.2 kW
004	0.4 kW
007	0.75 kW
015	1.5 kW
022	2.2 kW
030	3.0 kW
037	3.7 kW
040	4.0 kW
055	5.5 kW
075	7.5 kW
110	11 kW
150	15 kW
185	18.5 kW
220	22 kW

Voltage class

B	Single-phase 200 VAC (200-V class)
2	3-phase 200 VAC (200-V class)
4	3-phase 400 VAC (400-V class)

Enclosure rating

A	Panel-mounting or closed wall-mounting models
---	---

### 3G3M1-A□□□□-ECT

3 G 3 M 1 - A 2 0 0 1 - E C T

Maximum applicable motor capacity (HHD rating)

001	0.1 kW
002	0.2 kW
004	0.4 kW
007	0.75 kW
015	1.5 kW
022	2.2 kW
030	3.0 kW
037	3.7 kW
040	4.0 kW
055	5.5 kW
075	7.5 kW
110	11 kW
150	15 kW
185	18.5 kW
220	22 kW

Voltage class

B	Single-phase 200 VAC (200-V class)
2	3-phase 200 VAC (200-V class)
4	3-phase 400 VAC (400-V class)

Enclosure rating

A	Panel-mounting or closed wall-mounting models
---	---

# M1 Series

## Ordering Information

### M1 series Inverter Models

#### Standard Type

Rated voltage	Enclosure ratings	Max. applicable motor capacity		Model
		HHD: Heavy load	HND: Light load	
3-phase 200 VAC	IP20	0.1 kW	0.2 kW	3G3M1-A2001
		0.2 kW	0.4 kW	3G3M1-A2002
		0.4 kW	0.75 kW	3G3M1-A2004
		0.75 kW	1.1 kW	3G3M1-A2007
		1.5 kW	2.2 kW	3G3M1-A2015
		2.2 kW	3.0 kW	3G3M1-A2022
		3.7 kW	5.5 kW	3G3M1-A2037
		5.5 kW	7.5 kW	3G3M1-A2055
		7.5 kW	11 kW	3G3M1-A2075
		11 kW	15 kW	3G3M1-A2110
		15 kW	18.5 kW	3G3M1-A2150
3-phase 400 VAC	IP20	0.4 kW	0.75 kW	3G3M1-A4004
		0.75 kW	1.1 kW	3G3M1-A4007
		1.5 kW	2.2 kW	3G3M1-A4015
		2.2 kW	3.0 kW	3G3M1-A4022
		3.0 kW	4.0 kW	3G3M1-A4030
		4.0 kW	5.5 kW	3G3M1-A4040
		5.5 kW	7.5 kW	3G3M1-A4055
		7.5 kW	11 kW	3G3M1-A4075
		11 kW	15 kW	3G3M1-A4110
		15 kW	18.5 kW	3G3M1-A4150
		18.5 kW	22 kW	3G3M1-A4185
1-phase 200 VAC	IP20	0.1 kW	0.2 kW	3G3M1-AB001
		0.2 kW	0.4 kW	3G3M1-AB002
		0.4 kW	0.55 kW	3G3M1-AB004
		0.75 kW	1.1 kW	3G3M1-AB007
		1.5 kW	2.0 kW	3G3M1-AB015
		2.2 kW	2.7 kW	3G3M1-AB022
		3.7 kW	---	3G3M1-AB037

## Built-in EtherCAT Communications Type



Rated voltage	Enclosure ratings	Max. applicable motor capacity		Model
		HHD: Heavy load	HND: Light load	
3-phase 200 VAC	IP20	0.1 kW	0.2 kW	3G3M1-A2001-ECT
		0.2 kW	0.4 kW	3G3M1-A2002-ECT
		0.4 kW	0.75 kW	3G3M1-A2004-ECT
		0.75 kW	1.1 kW	3G3M1-A2007-ECT
		1.5 kW	2.2 kW	3G3M1-A2015-ECT
		2.2 kW	3.0 kW	3G3M1-A2022-ECT
		3.7 kW	5.5 kW	3G3M1-A2037-ECT
		5.5 kW	7.5 kW	3G3M1-A2055-ECT
		7.5 kW	11 kW	3G3M1-A2075-ECT
		11 kW	15 kW	3G3M1-A2110-ECT
		15 kW	18.5 kW	3G3M1-A2150-ECT
3-phase 400 VAC	IP20	0.4 kW	0.75 kW	3G3M1-A4004-ECT
		0.75 kW	1.1 kW	3G3M1-A4007-ECT
		1.5 kW	2.2 kW	3G3M1-A4015-ECT
		2.2 kW	3.0 kW	3G3M1-A4022-ECT
		3.0 kW	4.0 kW	3G3M1-A4030-ECT
		4.0 kW	5.5 kW	3G3M1-A4040-ECT
		5.5 kW	7.5 kW	3G3M1-A4055-ECT
		7.5 kW	11 kW	3G3M1-A4075-ECT
		11 kW	15 kW	3G3M1-A4110-ECT
		15 kW	18.5 kW	3G3M1-A4150-ECT
		18.5 kW	22 kW	3G3M1-A4185-ECT
1-phase 200 VAC	IP20	0.1 kW	0.2 kW	3G3M1-AB001-ECT
		0.2 kW	0.4 kW	3G3M1-AB002-ECT
		0.4 kW	0.55 kW	3G3M1-AB004-ECT
		0.75 kW	1.1 kW	3G3M1-AB007-ECT
		1.5 kW	2.0 kW	3G3M1-AB015-ECT
		2.2 kW	2.7 kW	3G3M1-AB022-ECT
		3.7 kW	---	3G3M1-AB037-ECT

# M1 Series

## Recommended EtherCAT Communications Cables

Use a straight STP (shielded twisted-pair) cable of category 5 or higher with double shielding (aluminum tape and braiding) for EtherCAT.

### Cable with Connectors

Item		Recommended manufacturer	Cable length (m)	Model
Wire gauge and number of pairs: AWG26, 4-pair cable Cable sheath material: PUR	Cable with Connectors on Both Ends (RJ45/RJ45) Standard RJ45 plugs *1 Cable color: Yellow *2 	OMRON	0.3	XS6W-6PUR8SS30CM-YF
			0.5	XS6W-6PUR8SS50CM-YF
			1	XS6W-6PUR8SS100CM-YF
			2	XS6W-6PUR8SS200CM-YF
			3	XS6W-6PUR8SS300CM-YF
			5	XS6W-6PUR8SS500CM-YF
Wire gauge and number of pairs: AWG22, 2-pair cable	Cable with Connectors on Both Ends (RJ45/RJ45) Rugged RJ45 plugs *1 Cable color: Light blue 	OMRON	0.3	XS5W-T421-AMD-K
			0.5	XS5W-T421-BMD-K
			1	XS5W-T421-CMD-K
			2	XS5W-T421-DMD-K
			5	XS5W-T421-GMD-K
	Cable with Connectors on Both Ends (M12 Straight/RJ45) Shield strengthening connector cable *3 M12/Smartclick connector and rugged RJ45 plug Cable color: Black 	OMRON	0.5	XS5W-T421-BMC-SS
			1	XS5W-T421-CMC-SS
			2	XS5W-T421-DMC-SS
			3	XS5W-T421-EMC-SS
			5	XS5W-T421-GMC-SS
10	XS5W-T421-JMC-SS			

\*1. Cables with standard RJ45 plugs are available in the following lengths: 0.2 m, 0.3 m, 0.5 m, 1 m, 1.5 m, 2 m, 3 m, 5 m, 7.5 m, 10 m, 15 m, 20 m. Cables with rugged RJ45 plugs are available in the following lengths: 0.3 m, 0.5 m, 1 m, 2 m, 3 m, 5 m, 10 m, 15 m.

For details, refer to *the Industrial Ethernet Connectors Catalog* (Cat. No. G019).

\*2. Cable colors are available in yellow, green, and blue.

\*3. For details, contact your OMRON representative.

### Cables/Connectors

Item	Recommended manufacturer	Model
Wire gauge and number of pairs: AWG24, 4-pair cable	Cable	Hitachi Metals, Ltd. <b>NETSTAR-C5E SAB0.5x4P CP *1</b>
	RJ45 Connector	Kuramo Electric Co. <b>KETH-SB *1</b>
Wire gauge and number of pairs: AWG22, 2-pair cable	Cable	Panduit Corporation <b>MPS588-C *1</b>
	Cable	Kuramo Electric Co. <b>KETH-PSB-OMR *2</b>
		JMACS Japan Co., Ltd. <b>PNET/B *2</b>
RJ45 Assembly Connector 	OMRON <b>XS6G-T421-1 *2</b>	

\*1. We recommend you to use the above Cable and RJ45 Connector together.

\*2. We recommend you to use the above Cable and RJ45 Assembly Connector together.



---

## Software

### Automation Software Sysmac Studio

The Sysmac Studio is the software that provides an integrated environment for setting, programming, debugging and maintenance of machine automation controllers including the NJ/NX-series CPU Units, NY-series Industrial PC, EtherCAT Slave, and the HMI.

For details, refer to your local OMRON website and Sysmac Studio Catalog (Cat. No. P138).

**Note:** The M1 Series is supported by Sysmac Studio version 1.52 or higher.

## M1 Series

### Related Manuals

Man. No.	Model	Manual
I669	3G3M1-A□□□□□	Multi-function Compact Inverter M1 Series Standard Type User's Manual
I670	3G3M1-A□□□□□-ECT	Multi-function Compact Inverter M1 Series Built-in EtherCAT® Communications Type User's Manual
W504	SYSMAC-SE2□□□	Sysmac Studio Version 1 Operation Manual
I589	SYSMAC-SE2□□□	Sysmac Studio Drive Function Operation Manual

## Terms and Conditions Agreement

### Read and understand this catalog.

Please read and understand this catalog before purchasing the products. Please consult your OMRON representative if you have any questions or comments.

### Warranties.

(a) Exclusive Warranty. Omron's exclusive warranty is that the Products will be free from defects in materials and workmanship for a period of twelve months from the date of sale by Omron (or such other period expressed in writing by Omron). Omron disclaims all other warranties, express or implied.

(b) Limitations. OMRON MAKES NO WARRANTY OR REPRESENTATION, EXPRESS OR IMPLIED, ABOUT NON-INFRINGEMENT, MERCHANTABILITY OR FITNESS FOR A PARTICULAR PURPOSE OF THE PRODUCTS. BUYER ACKNOWLEDGES THAT IT ALONE HAS DETERMINED THAT THE PRODUCTS WILL SUITABLY MEET THE REQUIREMENTS OF THEIR INTENDED USE.

Omron further disclaims all warranties and responsibility of any type for claims or expenses based on infringement by the Products or otherwise of any intellectual property right. (c) Buyer Remedy. Omron's sole obligation hereunder shall be, at Omron's election, to (i) replace (in the form originally shipped with Buyer responsible for labor charges for removal or replacement thereof) the non-complying Product, (ii) repair the non-complying Product, or (iii) repay or credit Buyer an amount equal to the purchase price of the non-complying Product; provided that in no event shall Omron be responsible for warranty, repair, indemnity or any other claims or expenses regarding the Products unless Omron's analysis confirms that the Products were properly handled, stored, installed and maintained and not subject to contamination, abuse, misuse or inappropriate modification. Return of any Products by Buyer must be approved in writing by Omron before shipment. Omron Companies shall not be liable for the suitability or unsuitability or the results from the use of Products in combination with any electrical or electronic components, circuits, system assemblies or any other materials or substances or environments. Any advice, recommendations or information given orally or in writing, are not to be construed as an amendment or addition to the above warranty.

See <http://www.omron.com/global/> or contact your Omron representative for published information.

### Limitation on Liability: Etc.

OMRON COMPANIES SHALL NOT BE LIABLE FOR SPECIAL, INDIRECT, INCIDENTAL, OR CONSEQUENTIAL DAMAGES, LOSS OF PROFITS OR PRODUCTION OR COMMERCIAL LOSS IN ANY WAY CONNECTED WITH THE PRODUCTS, WHETHER SUCH CLAIM IS BASED IN CONTRACT, WARRANTY, NEGLIGENCE OR STRICT LIABILITY.

Further, in no event shall liability of Omron Companies exceed the individual price of the Product on which liability is asserted.

### Suitability of Use.

Omron Companies shall not be responsible for conformity with any standards, codes or regulations which apply to the combination of the Product in the Buyer's application or use of the Product. At Buyer's request, Omron will provide applicable third party certification documents identifying ratings and limitations of use which apply to the Product. This information by itself is not sufficient for a complete determination of the suitability of the Product in combination with the end product, machine, system, or other application or use. Buyer shall be solely responsible for determining appropriateness of the particular Product with respect to Buyer's application, product or system. Buyer shall take application responsibility in all cases.

NEVER USE THE PRODUCT FOR AN APPLICATION INVOLVING SERIOUS RISK TO LIFE OR PROPERTY OR IN LARGE QUANTITIES WITHOUT ENSURING THAT THE SYSTEM AS A WHOLE HAS BEEN DESIGNED TO ADDRESS THE RISKS, AND THAT THE OMRON PRODUCT(S) IS PROPERLY RATED AND INSTALLED FOR THE INTENDED USE WITHIN THE OVERALL EQUIPMENT OR SYSTEM.

### Programmable Products.

Omron Companies shall not be responsible for the user's programming of a programmable Product, or any consequence thereof.

### Performance Data.

Data presented in Omron Company websites, catalogs and other materials is provided as a guide for the user in determining suitability and does not constitute a warranty. It may represent the result of Omron's test conditions, and the user must correlate it to actual application requirements. Actual performance is subject to the Omron's Warranty and Limitations of Liability.

### Change in Specifications.

Product specifications and accessories may be changed at any time based on improvements and other reasons. It is our practice to change part numbers when published ratings or features are changed, or when significant construction changes are made. However, some specifications of the Product may be changed without any notice. When in doubt, special part numbers may be assigned to fix or establish key specifications for your application. Please consult with your Omron's representative at any time to confirm actual specifications of purchased Product.

### Errors and Omissions.

Information presented by Omron Companies has been checked and is believed to be accurate; however, no responsibility is assumed for clerical, typographical or proofreading errors or omissions.