

Safety Information

Electrical equipment should be installed, operated, serviced, and maintained only by qualified personnel. No responsibility is assumed by Schneider Electric for any consequences arising out of the use of this material.



Esmi Impresia Base with Sounder

Esmi Impresia Base with Sounder (FFS06741016) is an addressable fire base with a built-in sounder and an isolator module in its body. The fire base is designed for installing in addressable fire alarm systems with Esmi ELC loop controller supporting Schneider Electric communication protocol. Esmi Impresia Base with Sounder fire base supports 32 different tone types at two sound levels. The tone type and sound level are programmed from the control panel. The device is compatible for operation with Esmi Impresia addressable detectors series: Esmi Impresia Heat Detector (FFS06741002), Esmi Impresia Smoke Detector (FFS06741001) and Esmi Impresia Multicriteria Detector (FFS06741003). The device is designed for easy installation and consists of two parts: a mounting plane basis and a sounder as a body with a factory mounted fire base. EN 54-3 for indoor use. The address setting is done by the panel, QR code or handheld addressing device. The address range is 1-250.

For more technical information visit www.se.com.

Installation Instructions

Note: Collect the QR code stickers from the devices if QR codes are used for addressing of the devices.

1. Follow the applicable local and national installation codes and regulations. Choose the proper place for installation of the device.
2. Turn power off the loop circuit before installing the base.
3. Set the module address using programmer or directly from addressable fire panel.
4. Fix the mounting plane basis on the ceiling of the protected premises using fixings according the mounting surface.
5. Run the loop wires and fix the sounder body to the mounting basis using the supplied screws in the spare parts kit.
6. Connect the fire base to the fire panel using the wiring diagram.
7. Insert a detector - Esmi Impresia Heat Detector (FFS06741002), Esmi Impresia Smoke Detector (FFS06741001) and Esmi Impresia Multicriteria Detector (FFS06741003) - into the fire base and rotate clockwise until it drops into place - the short mark on the base fits with that on the sounder body. Continue to rotate the detector until its mark coincides with the long mark on the base - a click is heard.
Note: The mounted detector on the Esmi Impresia Standard Base (FFS06741018) with sounder is assigned at different address to the control panel!
8. Program the sounder parameters.
9. Test the sounder for proper operation.

Dimensions

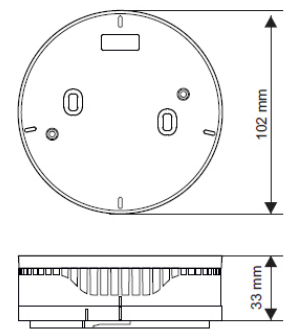

Installation

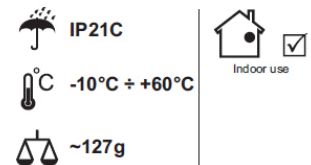

Technical Specifications

Operating Voltage Range	16 - 32VDC
Maximal consumption at communication	470 µA @ 27VDC
Maximal consumption:	
- main tone type 27, low volume level	2.8 mA @ 27VDC
- main tone type 27, high volume level*	9.8 mA @ 27VDC
Power volume (main tone type 27): low volume	~ 99dB (A) ± 4dB @ 1m
Power volume (other tone types): low volume	90-100dB ± 3dB @ 1m
Number of tone types	32
Wire Gauge for terminals	0.4mm ² ± 2.0mm ²
Relative humidity resistance	(93 ± 3)% @ +40°C
Color	White
Material	ABS
Supported communication protocol	Esmi ELC

* Note: Approved to EN54-3 only!

A-weighted sound level diagram

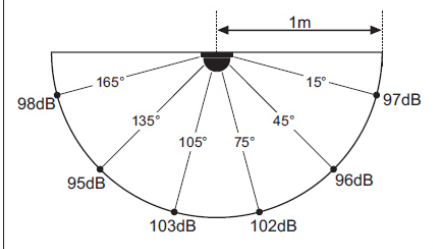

Isolator Module Technical Specifications

Maximum line voltage (<i>Vmax</i>)	32V
Nominal line voltage (<i>Vnom</i>)	28V
Minimum line voltage (<i>Vmin</i>)	16V
Maximum voltage at which the device isolates (<i>Vso max</i>)*	7.5V
Minimum voltage at which the device isolates (<i>Vso min</i>)*	5.9V
Maximum voltage at which the device reconnects (<i>Vsc max</i>)**	6.7V
Minimum voltage at which the device reconnects (<i>Vsc min</i>)**	5V
Maximum rated continuous current with the switch closed (<i>Ic max</i>)	0.7A
Maximum rated switching current (e.g. under short circuit) (<i>Is max</i>)	1.8A
Maximum leakage current with the switch open (isolated state) (<i>Ii max</i>)	16mA
Maximum series impedance with the switch closed (<i>Zc max</i>)	0.12 Ω @ 28VDC / 0.15 Ω @ 16VDC

* Note: Switches from closed to open

** Note: Switches from open to closed

CE 21

1293
DoP No: DP20032
Made in Bulgaria
EN 54-3:2001
EN 54-3:2001/A1:2002
EN 54-3:2001/A2:2006
EN 54-17:2005
EN 54-17:2005/AC:2007
Sounder Type: A

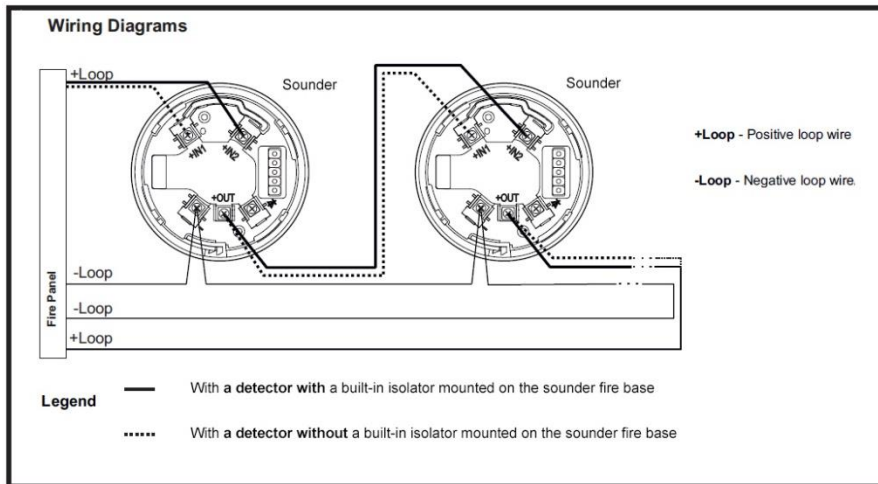
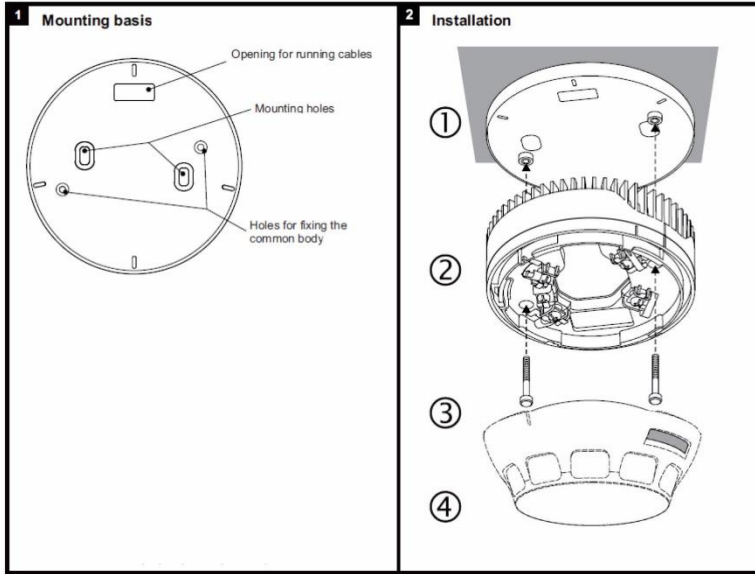

Tone	Tone Type	Tone Description/Application
1	[Solid line]	970Hz
2	[Square wave]	800Hz/970Hz @ 2Hz
3	[Sawtooth]	800Hz - 970Hz @ 1Hz
4	[Dashed line]	970Hz 1s OFF/1s ON
5	[Square wave]	970Hz, 0.5s/ 630Hz, 0.5s
6	[Square wave]	554Hz, 0.1s/ 440Hz, 0.4s (AFNOR NF S 32 001)
7	[Sawtooth]	500 - 1200Hz, 3.5s/ 0.5s OFF (NEN 2575:2000)
8	[Dashed line]	420Hz 0.625s ON/0.625s OFF (Australia AS1670 Alert tone)
9	[Sawtooth]	500 - 1200Hz, 0.5s/ 0.5s OFF x 3/1.5s OFF (AS1670 Evacuation)
10	[Square wave]	550Hz/440Hz @ 0.5Hz
11	[Dashed line]	970Hz, 0.5s ON/0.5s OFF x 3/ 1.5s OFF (ISO 8201)
12	[Dashed line]	2850Hz, 0.5s ON/0.5s OFF x 3/1.5s OFF (ISO 8201)
13	[Sawtooth]	1200Hz - 500Hz @ 1Hz (DIN 33 404)
14	[Solid line]	400Hz
15	[Square wave]	550Hz, 0.7s/1000Hz, 0.33s
16	[Sawtooth]	1500Hz - 2700Hz @ 3Hz
17	[Solid line]	750Hz
18	[Solid line]	2400Hz
19	[Solid line]	660Hz
20	[Dashed line]	660Hz 1.8s ON/1.8s OFF
21	[Dashed line]	660Hz 0.15s ON/0.15s OFF
22	[Square wave]	510Hz, 0.25s/ 610Hz, 0.25s
23	[Square wave]	800/1000Hz 0.5s each (1Hz)
24	[Sawtooth]	250Hz - 1200Hz @ 12Hz
25	[Sawtooth]	500Hz - 1200Hz @ 0.33Hz
26	[Sawtooth]	2400Hz - 2900Hz @ 9Hz
27*	[Sawtooth]	2400Hz - 2900Hz @ 3Hz 2500Hz (main sound frequency)
28	[Sawtooth]	800Hz - 970Hz @ 100Hz
29	[Sawtooth]	800Hz - 970Hz @ 9Hz
30	[Sawtooth]	800Hz - 970Hz @ 3Hz
31	[Dashed line]	800Hz, 0.25s ON/1s OFF
32	[Sawtooth]	600Hz - 1100Hz, 2.6s/0.4s OFF

* Note: Approved to EN 54-3 only!

Spare Parts

Esmi Impresia Plastic Lid Set of 5 pcs	FFS06741023
--	-------------